

## Compressor Thermostat Operation Manual



Please read this operation manual carefully and keep it properly



## Preface

Thank you very much for purchasing Ferrcool Thermostat. (herein referred to as the “product”). This manual describes the operation of the product. Please use this manual for efficient and long use of this unit. Be sure to read this manual efficiently for your deep understanding of overview and safety of this unit before installation or carrying out the relevant operations of this unit. Especially, you need to follow the instructions about “Danger”, “Warning” and “Caution”.

## Caution

This product is provided with “Warning” labels and “Caution” labels to inform the operator of hazards related to the product. Check the contents and position of all labels before starting the work.

### **WARNING**

The product shall be handled only by trained personnel only. Transportation, installation and maintenance including dangerous work shall be done by persons who have full knowledge and experience on the product and the system. Cover panels of the product shall be opened only by qualified service technicians or qualified personnel.

### **WARNING**

Read all warning and caution labels carefully and keep them in mind. Do not peel off or rub alert warning and caution labels. Confirm locations of alert warning and caution labels.

### **WARNING**

This product can not be used for the device related to food.

### **WARNING**

If abnormal conditions, such as abnormal noise or smoke, or water leakage appeared, take the following actions:

- 1、Shut down power.
- 2、Stop water radiating water supply
- 3、Contact an authorized Ferrotec dealer for repair

## Packaged items

No.	Item	Qty.
1	Product	1
2	Filter component (optional)	1
3	Mounting bracket	2
4	Operation Manual	1
Different models have different accessories		



---

Contents	Contents	Page No.
1. Introduction .....		01
1.1. Scope and general description of use .....		01
1.2. Operation by external communication .....		01
1.3. Contents of operation manual.....		02
2. Safety Instructions .....		03
2.1. Before using the Chiller.....		03
2.2. “Warning” label and “Caution” label .....		05
2.3. Disposing of waste.....		06
3. Installation precautions .....		07
3.1. Transportation, handling, moving .....		07
3.2. Environment.....		08
3.3. Piping.....		09
4. Unit Overview .....		10
4.1. Method of identifying model.....		10
4.2. Model No. label.....		10
4.3. Appearance .....		11
4.4. Outline of operation .....		12
4.5. Functions.....		13
5. Names and Functions of Components.....		14
5.1. Part layart .....		14
6. Specifications .....		15
6.1. Specification table.....		15
6.2. Performance chart.....		17

---

---

Contents	Page No.
7. Preparation for Operation.....	18
7.1. Preparation for circulating fluid.....	18
7.2. Power supply.....	19
7.3. Grounding .....	19
7.4. Supply circulating fluid and drain.....	19
7.5. Check. Repair.....	20
8. Operation.....	22
8.1. Power up.....	22
8.2. How to operate.....	21
9. Alarm.....	45
9.1. Alarm code list.....	45
10. Appendix.....	47
10.1. Signal and style of connectors .....	47
10.2. Calculation of dew point (from psychometric chart).....	48
10.3. Power Supply Cable.....	48
10.4. Refrigerant temperature and pressure comparison table.....	49

---

## Abbreviations

Abbreviation	Meaning
AC	Alternating Current
AT	Auto Tuning
Chap.	Chapter
DC	Direct Current
EMI	Electro Magnetic Interference
EPDM	Ethylene Propylene Diene Monomer
ERR	Error
IEC	International Electrotechnical Commission
LCD	Liquid Crystal Display
PE(Electricity)	Protective Earth
PE(Material)	Polyethylene
PID	Proportional, Integral, Differentiate
PPS	Polyphenylene Sulfide
PV	Process Value
RET	Return
RXD	Received Data
SEL	Select
SER(No.)	Serial(No.)
SG	Signal Ground
SUS	Special Use Stainless steel
SV	Setting Value
Temp.	Temperature
TXD	Transmitted Data
WRN	Warning

## 1. Introduction

The definition and construction of operation manual are described below.

### 1.1. Scope and general description of use

The operation manual applies to operation method of FerroTec-brand Chiller FCCW10311.

Chiller is air-to-liquid heat exchanger to be used to control the temperature (e.g. detectors in an X-Ray system) . It aims easier understanding of operational and Installation information of the Chiller. Before any operation and Installation of this unit, be sure to read this operation manual carefully and understand the contents well.

### 1.2. Operation by external communication

The content which can be communicated is as follows.

- 1) Setting and reading of target temperature
- 2) Reading of the value detected by temperature sensor
- 3) Reading of warning status
- 4) Setting and reading of off-set value

For operation by communication, it is necessary to order "Communication Specifications".

#### <Contact>

If you have any questions or are unclear about any of the content of this manual, please contact the following department.

Thermal-electric R&D department

Hangzhou Dahe Thermo-Magnetics Co., Ltd

Address: 668# Binkang Rd., Binjiang District, Hangzhou, China

TEL: +86-0571-86695070

Zip Code: 310053

<http://www.ferrotec.com.cn>

### 1.3. Contents of operation manual

#### 1) Chap.1 Introduction

The definition and use of operation manual are described.

#### 2) Chap.2 Safety Instructions

Safety instruction, caution note, danger and warning, warning label and caution label and safety interlock used in this unit are described.

#### 3) Chap.3 Caution on Installation

The precautions for setting up and mounting this unit are described.

#### 4) Chap.4 Unit Overview

Describe the outlook of this unit and operation overview.

#### 5) Chap.5 Names and Functions of Components

The description and function of the parts in this unit are mentioned.

#### 6) Chap.6 Specifications

The specifications of this unit are described.

#### 7) Chap.7 Preparation for Operation

The precautions for operation of this unit are described by each part.

#### 8) Chap.8 Operation

The method for operation of this unit is explained.

#### 9) Chap.9 Alarm

The alarms, which arise in this unit, are explained.

#### 10) Chap.10 Appendix

The signal of connectors and the method for calculating dew points are described.

## 2. Safety Instructions

### 2.1. Before using the Chiller

This chapter is dedicated for your safety during interaction with the product. The product is operated at high voltage. Therefore, not only those who operate the unit, but those who are in charge of service and who work nearby the product should read carefully and thoroughly understand descriptions related to safety in this manual before starting the work.

#### 2.1.1. Safety training

This manual is not a general manual for safety and hygiene education that safety and hygiene tutors are supposed to conduct. Anyone working with or near the product should be fully trained in recognition of the danger inherent to the product and the related safety counter measures. A manager is responsible for strict compliance to the safety standard in whole system, but individual person in charge of operation and maintenance should take responsibility for the daily work and should consider the safety of the working location and environment.

Operators and maintenance personnel responsible should ensure the safety of workshops and their environment before starting work.

Training concerning the product should take place after the sufficient training on safety. The training must not be carried without consideration to safety.

#### 2.1.2. Identification of “Danger”, “Warning”, “Caution” and “Note”

The notifications given in this operation manual aim to assure the safe and correct operation of the product to prevent injury of operators or damage to the product. The notifications are grouped into four categories, “Danger”, “Warning”, “Caution”, and “Note”, which indicate the severity of the hazard and damage and also the degree of emergency. All notifications contain critical matter on safety, so they shall be carefully observed. DANGER, WARNING, CAUTION and NOTE signs are in order according to severity (DANGER> WARNING>CAUTION>NOTE).

Table2-1 Division of DANGER, WARNING, CAUTION, and NOTE









	<p>These paragraphs highlight hazards that would cause serious or even fatal injuries to workers if handled improperly or important instructions are ignored.</p>
	<p>These These paragraphs highlights hazards that might cause serious injuries to workers if the appropriate procedure is not carried out or warnings are ignored.</p>
	<p>These paragraphs highlights hazards that might cause serious injuries to workers or might damage the unit, installed devices or products if the appropriate procedure is not carried out or cautions are ignored.</p>
	<p>These paragraphs highlight knowledge which is recommended to be known to avoid mistakes that likely to happen during operation. Also anything that might damage the unit or performance of product for checking is described.</p>

Table2-2 Meaning of symbols

	<p>This symbol warns of the danger of electric shock. There are high voltage and uncovered terminals inside the product.</p> <ul style="list-style-type: none"> <li>• Do not operate the product with the cover panels removed.</li> <li>• Do not operate inside unless trained and qualified personnel.</li> </ul>
	<p>This symbol warns of the danger of burns. This product may become hot during operation and may be burnt due to contact. Moreover, after turning off the power supply, it may cause burns due to residual heat. Do not operate the product with the cover removed. Do not operate inside until the temperature of the hot part drops.</p>
	<p>This symbol warns that rotating objects may cut or pinch fingers or hands. The fan rotates during the operation of the product (in the case of air-cooled models). Moreover, the fan may stop temporarily while running, but it will rotate again. Do not operate the product with the cover panels removed.</p>
	<p>This symbol warns of other dangers. Internal danger warning High temperature—The high temperature part of this product is inside. Rotating fan—This unit is inside (air-cooled models). High voltage—This product has a high voltage liquid inside. Do not operate the product with the cover panels removed.</p>

## 2.2. “Warning” label and “Caution” label

This product is provided with “Warning” labels and “Caution” labels to inform the operator of hazards related to the product. Check the contents and position of all labels before starting the work.

### **WARNING**

The product shall be handled only by trained personnel only. Transportation, installation and maintenance including dangerous work shall be done by persons who have full knowledge and experience on the product and the system. Cover panels of the product shall be opened only by qualified service technicians or qualified personnel.

### **WARNING**

Read all warning and caution labels carefully and keep them in mind. Do not peel off or rub alert warning and caution labels. Confirm locations of alert warning and caution labels.

### **WARNING**

This product can not be used for the device related to food.

### **WARNING**

If abnormal conditions, such as abnormal noise or smoke, or water leakage appeared, take the following actions:

- 1、 Shut down power.
- 2、 Stop water radiating water supply.
- 3、 Contact an authorized Ferrotec dealer for repair.

### 2.2.1. The position of attached “Warning” label and “Caution” label

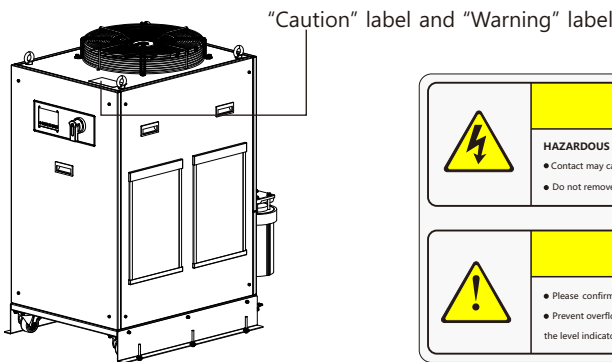

Fig.2-1 The position of attaching “Warning”

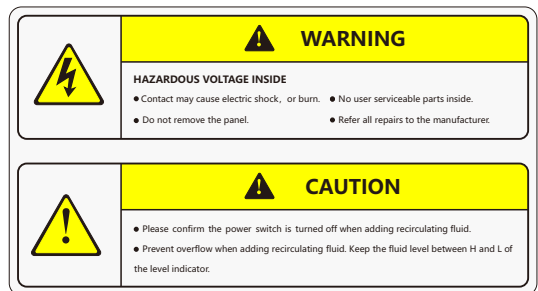

Fig.2-2 Detail of “Warning” and “Caution” label

## 2.3. Disposing of waste

### 2.3.1.Recovery of refrigerant and lubricating oil

This product is Refrigerant recovery and destruction method Class I specific product. This product uses HFC and refrigerant oil.

Please read the following instructions carefully and fully understand when collecting. Please contact your dealer if you have any questions.

#### **WARNING**

Cover panels of the product shall be opened only by qualified service technicians or qualified personnel.

Do not discard refrigerant oil with domestic waste. Moreover, do not burn in an unauthorized incinerator.

#### **WARNING**

Dispose of HFC and refrigerant oil according to the local laws or regulations. The discharge of HFC into the atmosphere is prohibited by law. After using the "refrigerant recovery device" to recover HFC, the relevant professionals should handle the recovered HFC. Refrigerant recovery and refrigerant oil recovery should be completed by persons who have full knowledge and experience on the product and the accessories.

### 2.3.2.The discard of this product

Contact the industrial waste treatment company to dispose of this product. Please drain the liquid to minimize the risk when the product is scrapped. It may cause an accident or damage during transportation if the fluid remains inside.

### 2.3.3.Material Safety Data Sheet (MSDS)

Please contact your dealer if you need this product's MSDS.

Please prepare your own MSDS.

### 3. Installation precautions

#### **⚠ WARNING**

Only personnel with sufficient knowledge and experience of the product and system should handle and install the product. Please pay special attention to the safety of all personnel.

#### 3.1 Transportation, handling, moving

Because the product is heavy, there is danger in transportation. In addition, in order to prevent damage or failure of this product, please be sure to comply with the following when transporting this product.

##### ① Handle with forklift

1. Please use a qualified driver to operate the forklift.
2. The insertion position of the forklift varies according to the product.
3. Do not use a forklift truck to insert the external protection plate and pipe connection.

##### ② Handle by lifting

1. Please use qualified drivers to operate cranes and cranes.
2. Do not hold the pipe and plate handle on the right side of the product.
3. When lifting with the ring, be sure to carry out 4-point lifting.

Regarding the lifting Angle, pay attention to the position of the center of gravity, please control within 60°.

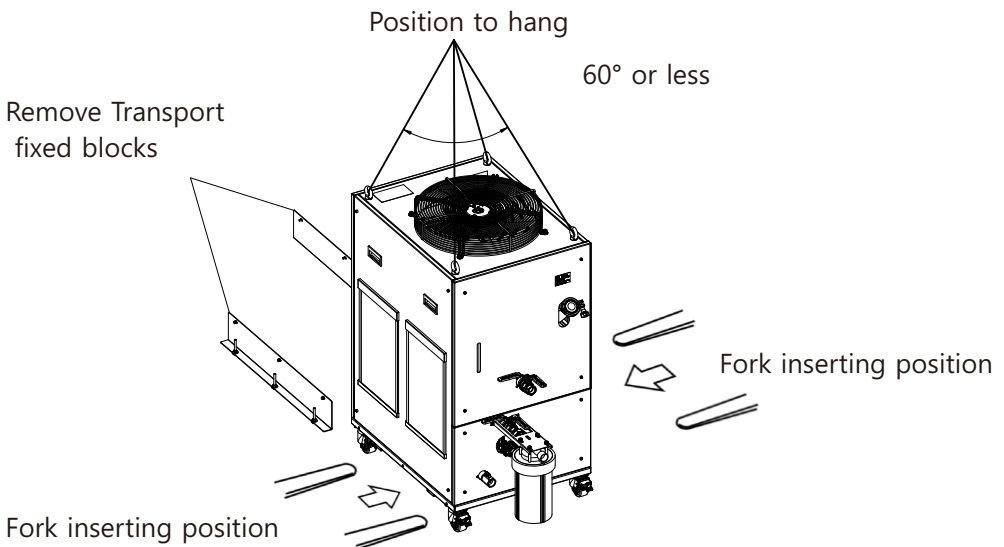

### ③ Carried by casters

1. This product is heavy, must be carried by more than 2 people.
2. Do not hold the pipe connection or the handle of the protection plate on the right side of the product.
3. When using a forklift, do not insert the pin wheel and adjustable foot seat, and ensure that they are inserted from the opposite side.
4. Do not use casters to cross the gap.



## CAUTION

Do not place horizontally. The lubricating oil in the compressor enters the refrigerant pipe, and the lubricating oil is insufficient, causing the compressor to fail. Please drain the residual liquid from the piping as much as possible. Residual liquid may overflow.

### 3.2. Environment

The product shall be installed in an environment that meets the following requirements.

- 1) Where the product is not exposed to water, oil or any chemical spills.
- 2) Where the product is installed horizontally in a stable position.
- 3) Where the product is installed without interfere the suction and discharge port.
- 4) Where the product is not exposed to corrosive or flammable gas. (The unit is not explosion proof.)
- 5) Where the ambient temperature range is between 5 to 40 °C and the relative humidity range is between 30 to 70%. No dew condensation is allowed on the unit.
- 6) Where the product is not exposed to noise sources (such as discharging equipment, large relay and thyristor).
- 7) Where the there is enough space between power supply cable and communication cable of the product and power cables of other equipments.
- 8) Where the product is not exposed to strong electrical or magnetic emissions.
- 9) Where the power supply and ground connections can be made correctly.
- 10) Where the product is not exposed to materials such as silicone, which may generate harmful gas.
- 11) Where the product is not outdoors or in a place with the direct sunshine or heat radiation.
- 12) Where the product is forbidden to be used with a height of more than 3000 meters ( Except for storage and transportation ). When the altitude is 1000 meters or higher, the specific gravity of the air decreases, the heat dissipation performance of the product condenser decreases. There is an upper limit of the ambient temperature, and the cooling capacity decreases.

### 3.3. Piping

- 1) Ensure the flow rate of the circulating fluid is as high as possible to maintain the temperature stability. Therefore, the length of the external piping should be minimized and internal diameter should be as large as possible. Piping must have sufficient strength for the maximum discharge pressure of the circulating circuit.
- 2) Likewise, if a tube is bent or multiple elbow fittings are used, the piping resistance will increase and the flow rate will decrease. If the flow rate falls, the temperature stability will decrease.
- 3) If installing a tank externally, only a sealed tank should be used .Do not use an open tank.

**⚠ CAUTION**

Ensure that the INLET and OUTLET for circulating fluid is connected correctly. If any valves are used ensure that they do not restrict the flow, otherwise low flow may cause an alarm.

**⚠ CAUTION**

Use water that satisfies the quality standards shown below for circulating water. If other liquids are used, the product could be damaged and leak fluid, resulting in electrical shock or earth leakage.

Table 3-1 Quality standard for fresh water (tap water)

Quality Item	Item	Standard value
	pH(25°C)	6.5 to 8.2
	Electric conductivity (25°C) (μS/cm)	100 to 800
	Chloride ion (mgCl-/L)	200 or less
	Sulphate ion (mgSO 42-/L)	200 or less
	Acid consumption (pH4.8) (mgCaCO3/L)	100 or less
	Total hardness (mgCaCO3/L)	200 or less
	Calcium hardness (mgCaCO3/L)	150 or less
	Ion silica (mgSiO2/L)	50 or less
	Iron (mgFe/L)	1.0 or less
	Copper (mgCu/L)	0.3 or less
	Sulphide ion (mgS2-/L)	None detected
	Ammonium ion (mgNH 4+/L)	1.0 or less
	Residual chlorine (mgCl/L)	0.3 or less
	Free carbon (mgCO2/L)	4.0 or less

## 4. Unit Overview

### 4.1. Method of identifying model

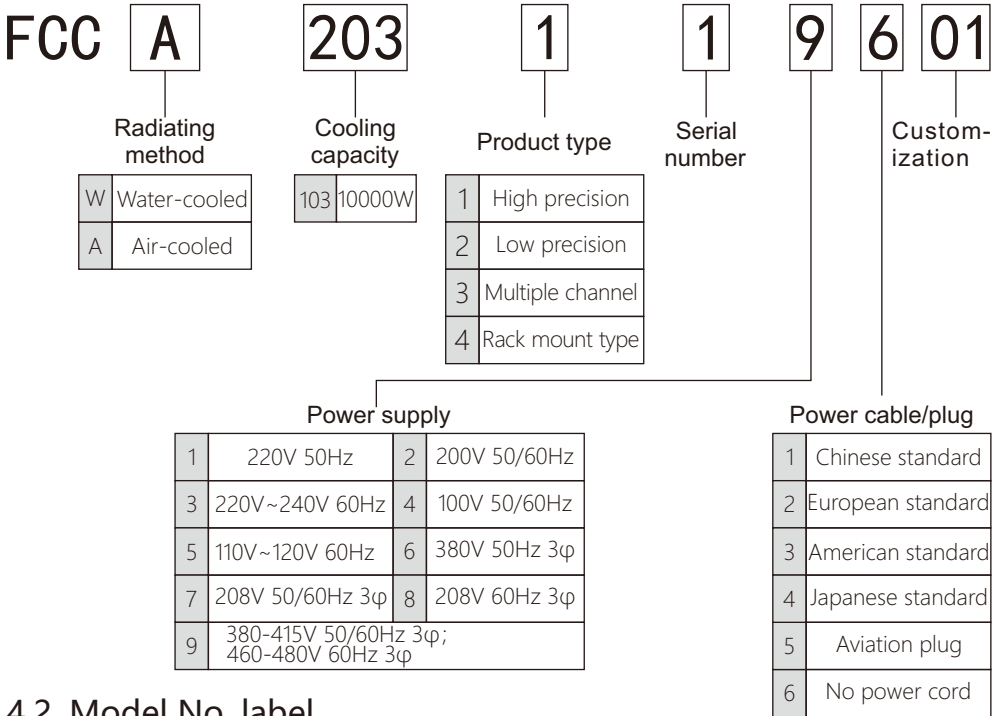

### 4.2. Model No. label

A model No. label is attached to the unit in the position shown below.

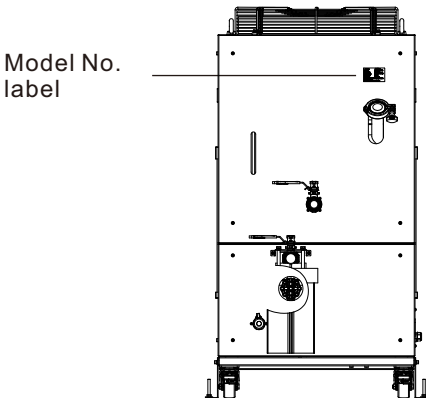

Fig.4-1 Position of Model No. label

<b>FerroTec</b>	<b>Chiller</b>
Model:	FCCA20311-9601
Serial No. :	0002
Refrigerant:	R410A/1.8kg
Rated Voltage:	AC380-415V 50/60Hz
Rated Current:	AC460-480V 60Hz
Rated Power:	13.7A
Net Weight:	7200W
Date:	190kg
Address:	2024.11.07
Address:	Add: 668#Binkang RD, Binjiang District, Hangzhou, China
Tel:	+86-0571-86696188
Http:	//www.ferrotc.com.cn
	Made in China

Fig.4-2 Example of Model No. label

### 4.3. Appearance

The appearance and the outline dimensions are as shown below.

FCCA10311/ FCCA20311

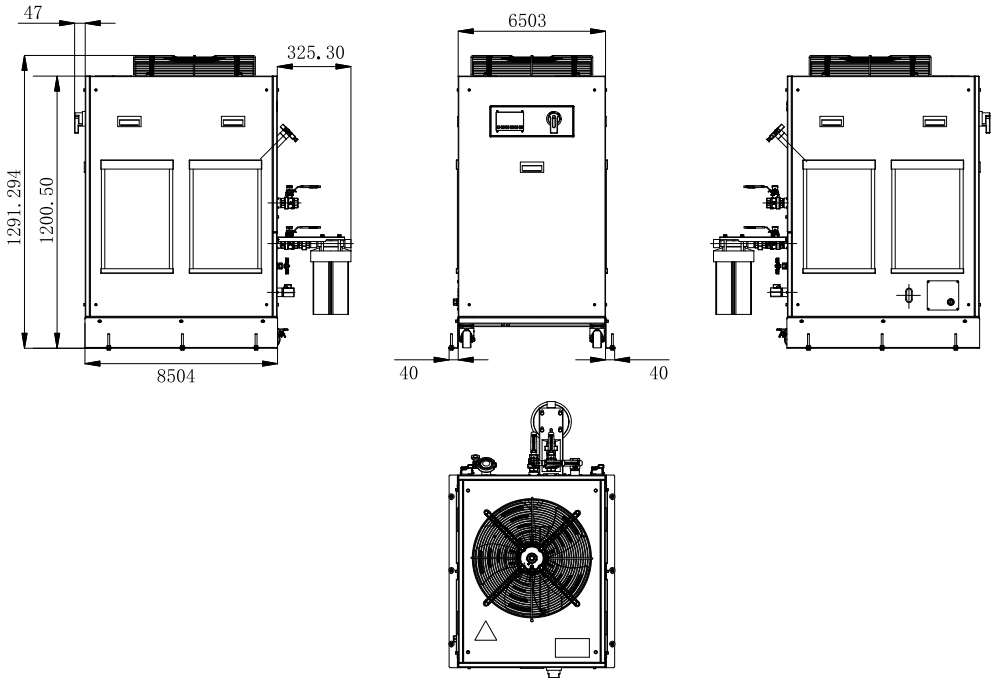

## 4.4. Outline of operation

The unit is operated as explained below.

### 4.4.1. Electrical diagram

The unit is equipped with electrical circuits as shown below.

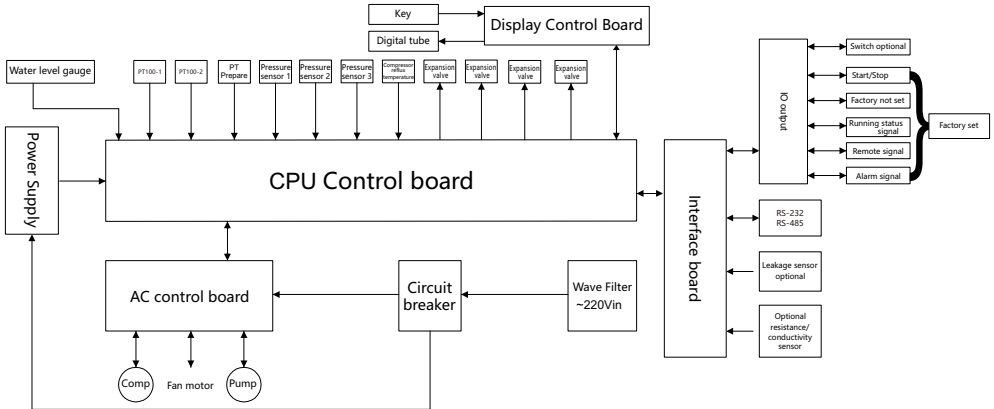

### 4.4.2. System

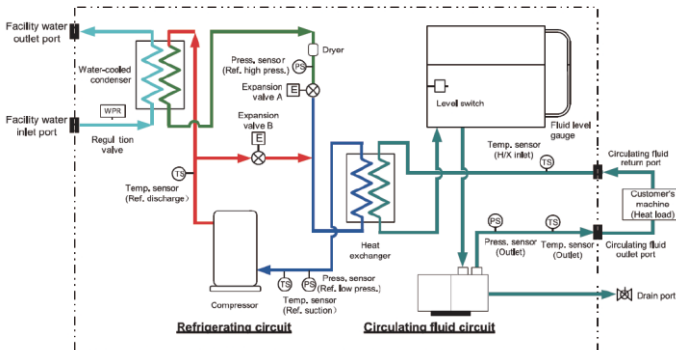

Water cooled circulating fluid system

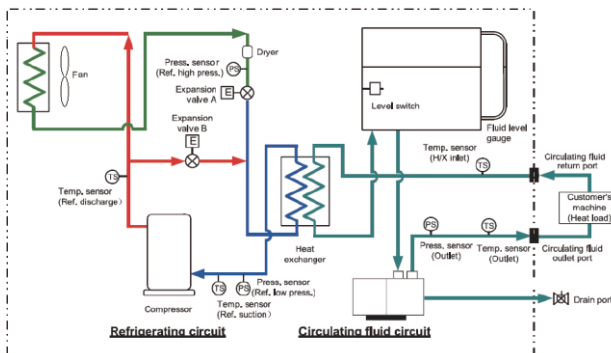

Air cooled circulating fluid system

## 4.5. Functions

### 4.5.1. Monitoring function

This function can monitor the inlet and outlet temperature of the circulating fluid, the suction temperature of the compressor, the outlet pressure of the circulating water, the high and low pressure of the refrigerant circuit, and the running time of the pump/fan/compressor/complete machine.

### 4.5.2. PID self-tuning function

The customer can adjust the PID parameters according to the actual use situation to achieve the best working state.

### 4.5.3. Locking function

In order to prevent misoperation and change the set value, the lock key can be set, which is only valid in the main interface.

### 4.5.4. Antifreeze function

The pump operates automatically when the circulating liquid temperature is less than 3 °C to prevent the circulating liquid from freezing in winter or at night. The pump stops when the temperature is higher than 5 °C.

### 4.5.5. Unit setting function

This function can change the temperature unit (°C/°F) and pressure unit (MPa/PSI), which is only valid in the main interface.

### 4.5.6. Temperature shift function

This function controls the temperature slide by an offset value from set point temperature. When the circulating fluid is carried to the target object, a certain deviation occurs between the temperature before the object and the setting temperature of the product due to the influence of ambient temperature on the piping. In this case, if the deviation is input as the offset value, the temperature of circulating fluid just before the object can match with setting value.

### 4.5.7. Alarm function

The product will alarm when there is an alarm item problem. When the problem is solved, the alarm can be reset. It is only valid in the alarm interface.

### 4.5.8. Optional function

Conductivity sensor component. The conductivity of deionized water (pure water) in the circulating fluid can be displayed and monitored, with a range of 0 ~ 50μ S/cm.

Bypass piping component. If the circulating fluid flow rate is insufficient, the temperature stability can't be achieved excellent. Please open the bypass piping to ensure flow in the situation.

## 5. Names and Functions of Components

The parts included into the unit have description and function individually.

### 5.1 Part layout

FCCA10311/ FCCA20311

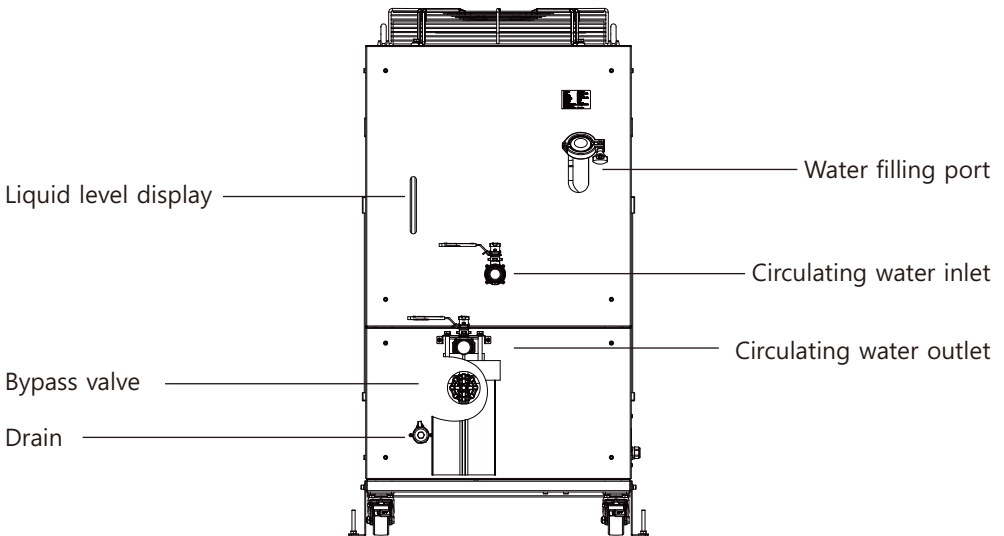
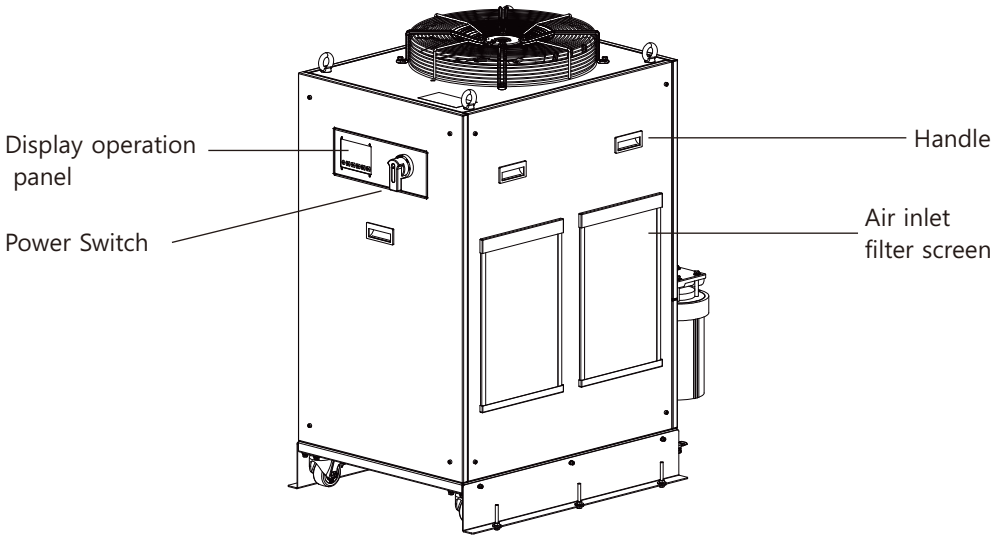

## 6. Specifications

### 6.1 Specification table

Air-cooled chiller specification table

Project		Specifications		
Model No.	FCCA10311	FCCA20311		
Cooling mode	Vapor compression refrigeration			
Heat dissipation mode	Air-cooled			
Control mode	PID control			
Ambient temperature/humidity	5°C-40°C , 35-70%RH			
Refrigerant	R410A			
Quantity of Refrigerant	1kg	1.3kg		
Circulating fluid system	Circulating fluid	Pure water/15% ethylene glycol in water		
	Operating temperature range	5.0-40.0°C		
	Cooling capacity※1	10KW	20KW	
	Heating capacity※1	1KW	2KW	
	Temperature stability※2	±0.1°C		
	Pump	45L/min(0.5MPa)		
	Tank volume	Approx 20L		
	Port size	IN/OUT	Rc1/Rc1	
		Drain	Rc1	
	Wetted parts material	EPDM, SUS 304, Cu , PVC, PTFE, POM		

Electrical system	Power supply	3-phase AC380~415V ( 50Hz/60Hz ) , 3-phase AC460~480V ( 60Hz )	
	Current overload protection	30A	
	Rated current	10A	16A
	Communications	I/O、RS232/RS485	
Weight		160kg	180kg
Accessories		/	

### 6-1 Specifications

※1 Environmental temperature 32°C, Cool water temperature 32°C,

Setting temperature 20°C, Circulating fluid flow rate 40 L/min

※2 Under stable load without turbulence

## 6.2 Performance chart

Value on performance chart is not guaranteed value but representative value. The value used for consideration should not be the very limit for the safety.

FCCA20311

1)Cooling capacity

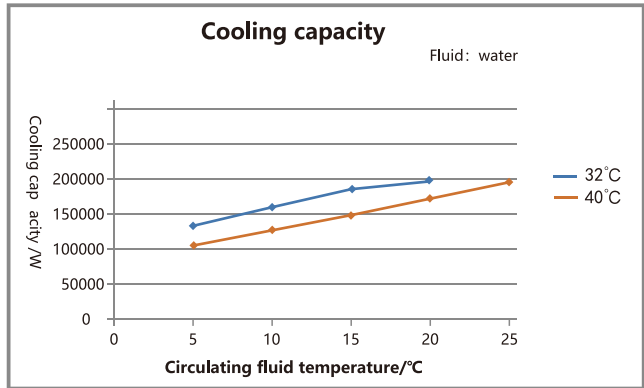

2)Pump capacity

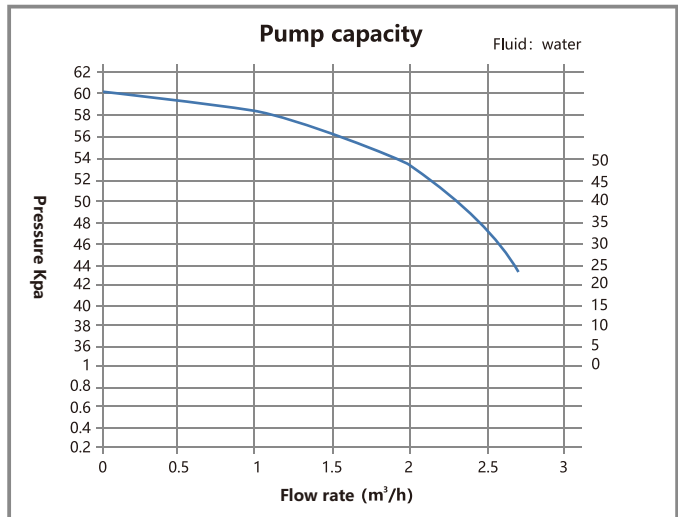

## 7. Preparation for Operation

### 7.1. Preparation for circulating fluid

The piping for circulating fluid is connected as below.

1. The piping for circulating fluid is located at the rear side face.
2. The same fittings are used for IN and OUT of the circulating fluid.

The fitting which can mate them needs to be prepared separately. When the fitting is connected, be sure to hold the fitting (block) mounted at Chiller with spanner, etc.

Thread size of fitting for circulating fluid: Rc1.

SUS 304 plug is mounted on DRAIN port for circulating fluid.

When the piping for drain is connected, remove this plug beforehand. Drain the circulating fluid before performing any maintenance.

Drain size : Rc1

### CAUTION

Fluid other than water or 15% ethylene glycol in water is not to be used as circulating fluid. Using such a fluid might lead to fluid leakage and damage of the pump.

### CAUTION

If a tank released to atmosphere is mounted outside, minimize the piping resistance at RETURN of circulating fluid. If the piping resistance is high, the causing the built-in reservoir of Chiller can have negative pressure resulting in deformation and crack. The built-in reservoir of Chiller is made of plastic and must not be subject to negative pressure larger than -0.02MPa.

---

## 7.2. Power supply

Power cord selection and installation based on on-site usage conditions The power supply cable shall be connected properly in accordance with Chapter 10 "Power Supply Cable".

## 7.3. Grounding

Be sure to provide the grounding. Use medical plug with protection earth when the unit is used for medical equipment. PE line of the power supply cable is available for grounding. Do not hold the ground in common with the ones for equipment which generates strong electromagnetic noise or high frequency.

## 7.4. Supply circulating fluid and drain

<Supply circulating fluid>

1. Confirm the power switch is turned off.
2. Take off the reservoir cap of the product.
3. Fill the circulating fluid for the reservoir. There is a possibility of spillage of circulating fluid. Pay attention when filling the circulating fluid. Stop the filling once the level of fluid reaches "H" level.
4. Turn on the power switch to fill the piping with the fluid.
5. When the piping is filled with the circulating fluid, the level of the reservoir lowers and low circulating fluid alarm (Low fluid level) arises accordingly. Then, turn off the power supply once again.
6. Repeat the step from 3 to 5 until alarm ( Low fluid level ) doesn't appear anymore. Then, replace the cap on the reservoir and tighten it securely.
7. Keep the fluid level between H and L of the level indicator.

<Drain circulating fluid>

1. Drain circulating fluid from the drain port. Open the reservoir cap would be helpful for draining.
2. To drain from the piping, blow the air (0.1MPa, about 1 minute) from Fluid IN to Fluid OUT. Tighten the tank lid and drain port while blowing.

**⚠ DANGER**

Never touch the switch with wet hands to avoid electrical shock.

**⚠ CAUTION**

Operation of the pump with the plenty of air left in the piping for prolonged period may cause the pump to break. Exhaust the air enough from the piping before starting operation of the pump. Take enough care not to spill the feed water over the case when supplying water to the reservoir. When it is spilt by mistake, wipe it off immediately and supply the power after it dries. If this procedure is neglected, it may cause break down of the equipment. Do not perform operation under the condition which lowers the flow rate significantly, such as closing the valve. Otherwise, the temperature might be beyond control.

**⚠ CAUTION**

If the fluid with low conductivity such as DI water is used as circulating fluid, it causes static electricity due to friction and damages the temperature sensor and other electric components of this unit. Take a measure to minimize static electricity from circulating fluid.

**⚠ CAUTION**

If the power switch is turned on without circulating fluid, the pump is damaged.

**⚠ CAUTION**

The product is damaged when driving for a long term with the temperature staggered periodically after reaching the target temperature. Please set the PID value again.

## 7.5. Check.Repair

The following checks shall be performed before operation.

### Daily check

- 1 ) Indication of display panel: Check temperature condition and confirm whether or not the alarm occurs.
- 2 ) Filter: Confirm there is not attachment of the dust on the filter at suction port. A lot of attachment may impair performance. We will recommend the removal of dust once every three months.
- 3 ) Check if the circulating fluid is dirty. Dirty circulating fluid may result in worse capacity or shorter product life. If water is used as the circulating fluid, algae and bacteria will be generated and dirty the circulating fluid. Therefore, replace the circulating fluid regularly (once a month as a guide).

- 4) Confirm there is no leakage of circulating fluid or no bending or crush of the piping of circulating fluid.
- 5) Confirm there is no abnormal sound or smell or abnormal heating of the case.

 **CAUTION**

Remove the dust attached to a filter by vacuum cleaner to prevent degrading of performance. The commended interval of removal is once per 3 months. Do not use water or boiled water since it leads to generation of rust at a frame.

 **CAUTION**

If the chiller is operated with bacteria and algae present, its cooling capacity or the capacity of the pump may deteriorate. Replace all circulating fluid regularly according to the conditions of water quality (once a month as a guide).

#### 7.5.1. Check after seismic vibration and impact

- 1) Piping: Confirm there is no defect including disconnection in piping.
- 2) Electrical wiring: Confirm there is disconnection of the connector from the cable.
- 3) Mounting condition: If the Chiller is mounted for operation, confirm the Chiller is mounted securely.
- 4) Circulating fluid: Confirm there is no leakage.
- 5) Others: Confirm there is no abnormal sound or smell or abnormal heating of the case.

#### 7.5.2. Repair and maintenance

The repair and maintenance services of this unit are performed only at our factory. The service requiring a trip regardless of inside and outside of China is not provided. Also, when this unit is returned for these purposes, drain the fluid from Chiller. Additionally, it is recommended to prepare spare units to minimize downtime due to those repair and maintenance services.

 **WARNING**

Drain the fluid from Chiller when it is returned for the repair and maintenance service. If the fluid is left inside, an accident and damage can result during transportation.

 **CAUTION**

After washing with DI water, return the product when the fluid was other than water. The acceptance might be refused according to the state of the product.

## 8. Operation

This chapter describes the detailed information on how to operate.

### 8.1. Power on

When power is turned on, the nixie tube will display a horizontal line for about 10 seconds, then go to the home page.

### ⚠ CAUTION

Please do not use devices that generate electromagnetic radiation such as cellular phones near the product. There is a possibility that the product malfunctions.

### 8.2. How to operate

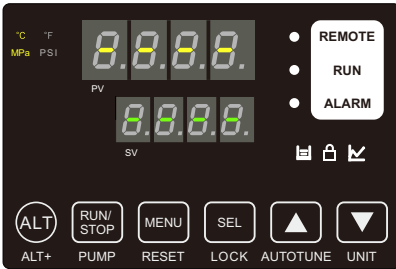

#### The home interface

[RUN/STOP] key: start or stop work.

[SEL] key: observe water outlet pressure. Press

[SEL] key again: displayed temperature.

[Up/Down]Key [▲] [▼]: used to change the set target temp. Other detailed key functions are shown in 8.2.1 and 8.2.2.



Long press [MENU] key: enter the inspection and monitoring interface. Short press [MENU] key: return to the main interface.

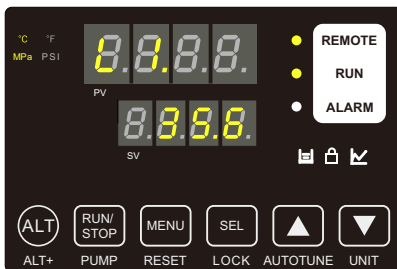

#### The inspection and monitoring interface

PV: parameter code.

SV: parameter data.

[SEL] key: switch parameter code. Detailed parameter code definitions are shown in 8.2.3.



Long press [MENU] key: enter the setting interface. Short press [MENU] key: return to the main interface.

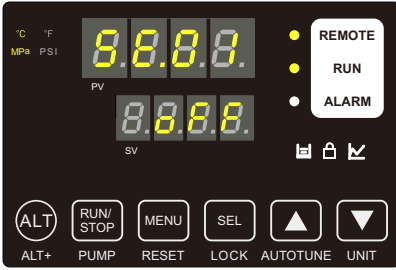

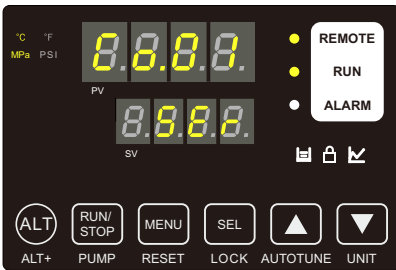

Long press [MENU] key: enter the communication setting interface. Short press [MENU] key: return to the main interface.



### The setting interface

PV: parameter code.

SV: current parameters.

[Up/Down]Key   : adjust the parameter setting status, automatic activation after parameter value flashes for 3 seconds.



[SEL] key: start now.

Detailed parameter code definitions are shown in 8.2.4.

### The communication setting interface

PV: parameter code.







SV: current parameters.

[Up/Down]Key   : adjust the parameter setting status, automatic activation after parameter value flashes for 3 seconds.

[SEL] key: start now.

Detailed parameter code definitions are shown in 8.2.5.

## 8.2.1. Operation panel

Item	Description		Category
Digital display unit ( 7 segment,4 bit )	PV	Display the current circulating fluid temperature, pressure, alarm code and other menu items (codes).	Panel
	SV	Display the setting value of circulating fluid output temperature or other menu settings.	
[ °C ] [ °F ] Light	Have unit switching function. Display unit of temperature(Ex-factory temp: °C).		
[ MPa ] [ PSI ] Light	Have unit switching function. Display unit of pressure(Ex-factory pressure: MPa).		
[ REMOTE ] Light	It can be operated remotely through communication function (Run/Stop). It lights up during remote operation.		
[ RUN ] Light	It lights up when running, and goes out when stopping. Flashes when the preparation is stopped, the antifreeze function is in standby, or the pump is running alone.		
[ ALARM ] Light	When an alarm occurs, the buzzer flashes.		
 Light	It lights up when the liquid level of the level gauge is less than the L scale.		
 Light	It lights up when the [LOCK] function is activated.		
 Light	It lights up when the [AUTOTUEN] function is activated.		
ALT Key	Shift key: combination can change key function		
RUN/STOP Key	Control run and stop of the device.		
MENU Key	Switch menu interface.		
SEL Key	Switch functions in the menu.		
	Change temperature, set parameters and change options.		
	Change temperature, set parameters and change options.		
ALT+RUN/STOP	Run the [PUMP] function: the separate operation switch of the water pump, which is invalid when the device is running.		
ALT+MENU	Run the [RESET] function: reset the alarm, which can only be operated in case of alarm.		
ALT+ SEL	Run the [LOCK] function: prevent the set value from being changed due to misoperation of the operator, set the lock key to prevent the setting from being changed, which is only valid in the main interface.		
ALT + 	Run the [AUTOTUNE] function: the PID self-tuning function, which is only valid when the device is running.		
ALT + 	Run the [UNIT] function to change the temperature (°C/°F) and pressure unit (MPa/PSI), which is only valid in the main interface.		

### 8.2.2.Home page

The first page: home page:

(Short press [MENU] key on any interface to return to the home page Short press [SEL] key to display P1 parameter, i.e. outlet pressure)

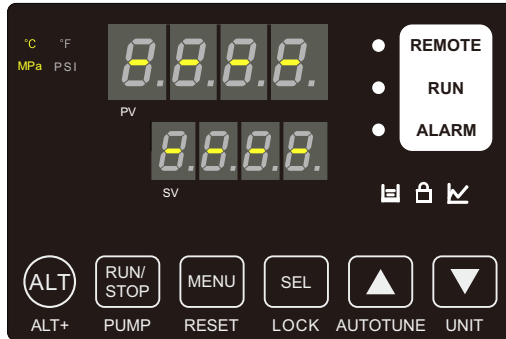

Item	Description	Category
Circulating fluid temp ( TEMP PV )	Display the actual temp of circulating fluid.	Home page Display the actual temp, the set temp and the outlet pressure of circulating fluid. Change the setting temperature of circulating fluid.
Circulating fluid setting temp ( TEMP SV )	Display the setting temp of circulating fluid.	
Circulating fluid outlet pressure P1	Display the outlet pressure of circulating fluid. (SEL key switch)	

### 8.2.3.Check monitoring interface

The second page: check the monitoring menu. (Long press [MENU] key: enter the inspection and monitoring interface Short press [MENU] key: return to the main interface Short press [SEL] key: change inspection items, which can only be viewed but set).

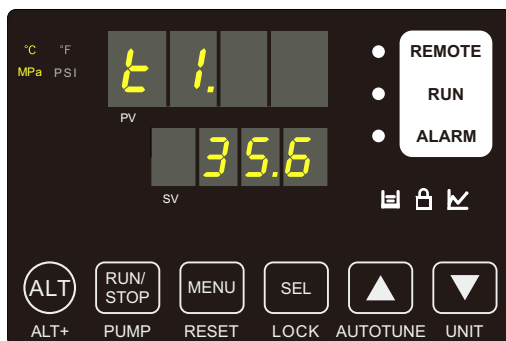

Code	Item	Description	Category
t1	Circulating fluid outlet temperature	Display the circulating fluid outlet temperature.	Check monitoring interface Confirm the temperature, pressure and cumulative operation time of the product every day.
t2	Circulating fluid inlet temperature	Display the circulating fluid inlet temperature.	
t3	Compressor suction temperature	Display compressor suction temperature.	
P1	Circulating fluid outlet pressure	Display the circulating fluid outlet pressure.	
PH	PH High pressure of refrigerant circuit	Display the high pressure of refrigerant circuit.	
PL	Low pressure of refrigerant circuit	Display low pressure of refrigerant circuit.	
PUMP	Accumulated time of pump operation	Display the accumulated time of pump operation.	
FAN.M	Accumulated running time of fan motor	Display the accumulated time of fan motor operation.	
rEF	Accumulated time of compressor operation	Display the accumulated time of compressor operation.	
dru	Cumulative running time	Display cumulative running time.	
Flow	Circulating fluid flow (Optional)	Display the circulating fluid flow	
Ec	Circulating fluid conductivity (Optional)	Display the circulating fluid conductivity	
t4	Compressor discharge temperature	Display the compressor discharge temperature	

### 8.2.4. Setup page

The third page: setup page. Long press [MENU] key: enter the setup page. Short press [MENU] key: return to the main interface. Short press [SEL] key: change inspection items, common function parameters can be set on the second page.



Code	Item	Description	Category
SE.01	READY mode	Set the ready signal (condition: READY bandwidth and READY time are met at the same time)	Setup page: set parameters of common functions.
SE.02	READY bandwidth	Set the temperature deviation of the prepared signal, and this function is closed at O.	
SE.03	READY time	Set the time of the preparation signal (the duration after the temperature reaches the temperature deviation range of the preparation), and the delay function is closed at O.	
SE.04	Offset mode	Set the offset mode by controlling the discharge temperature of the circulating liquid through the offset temperature.	
SE.05	Offset temperature	Set the offset temperature through the function of controlling the discharge temperature of the circulating liquid by the offset temperature.	
SE.06	Power failure recovery	When the power supply is cut off due to power failure, the function of resuming operation (on or off) in the state before the power supply is cut off after the power supply is restored.	
SE.07	Antifreeze function	The pump operates automatically when the temperature of circulating liquid is less than 3 °C, the circulating liquid is frozen in winter or at night, and the pump stops (on or off) when the temperature is greater than 5 °C.	
SE.08	Monitoring time of communication error	Set the monitoring time for the "communication error" alarm of alarm number AL12. When this monitoring time is exceeded, an alert will occur.	
SE.09	Restore data to factory settings	Reset all data. (The accumulated running time is not reset)	
SE.10	Pump operation cumulative time reset	Reset the accumulated time of pump operation.	
SE.11	Fan motor operation cumulative time reset	Reset the accumulated time of fan motor operation.	

Code	Item	Description	Category
SE.12	Reset the accumulated time of compressor operation	Reset the accumulated time of compressor operation.	
SE.13	"PID" adjustment "P" value	Proportional	
SE.14	"PID" adjustment "I" value	Integral	
SE.15	"PID" adjustment "D" value	Differentiate	
SE.16	Minimum temperature setting of circulating fluid	The lowest temperature alarm of circulating fluid can be set	
SE.17	Outlet Temperature Sensor Selection	Select "IN" for the "outlet water" connection. Select "OUT" for the standby connection.	
SE.18	Maximum limit setting of circulating fluid conductivity	The Maximum limit alarm of circulating fluid conductivity can be set	
SE.19	Maximum circulating fluid pressure	Setting the Maximum circulating fluid pressure	
SE.20	Minimum circulating fluid pressure	Setting the Minimum circulating fluid pressure	

## 1) READY mode

Set the setting temperature of the circulating liquid to the bandwidth temperature (upper and lower temperature range), and notify the circulating liquid temperature to reach the bandwidth (upper and lower temperature range) through communication, which can be set by the customer. Factory settings are disabled.

For example:

Set temperature of circulating fluid: 20 °C

READY bandwidth:  $\pm 2$  °C

READY time: 60 seconds

The circulating fluid is in the ready state after 60 seconds from 18 °C to 22 °C.

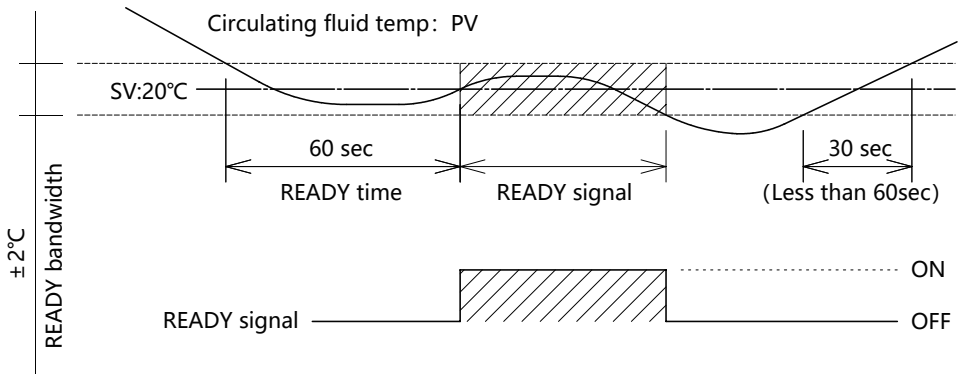

Code	Item	Description	Factory setting
SE.01	READY mode READY bandwidth ( Upper and lower temperature range )	Set ready signal. Set the temperature deviation of the prepared signal.	OFF
SE.02			0.0°C
SE.03	READY time	Set the time of signal	10 seconds

Set value	Description	Factory setting
OFF	Ready signal function OFF	0
ON	Ready signal function ON	

## 2) READY bandwidth (Upper and lower temperature range)

Set value	Description	Factory setting
-----	When READY mode is set to OFF, it cannot be set and confirmed.	
°C 0.0 ~ 5.0	The READY bandwidth corresponding to the set temperature of the circulating fluid can be set. (upper and lower temperature range)	0.0
°F 0.0 ~ 9.0		

## 3) READY time

Set value	Description	Factory setting
-----	When READY mode is OFF, it cannot be set and confirmed.	
10 ~ 9999	Set the arrival time. Set the unit as 1 sec.	10

## 4) Temperature shift function

The function of controlling the discharge temperature of circulating liquid through offset temperature. Depending on the installation environment, there may be temperature deviation between the product and the customer's equipment. In order to compensate for this temperature deviation, we provide three offset functions (MODE1 to 3). Factory settings are disabled.

For example:

The outlet water temperature of the circulating liquid is 30 ° C, but there will be 1 ° C heat loss in the process of transferring the circulating liquid to the customer's equipment side, then the temperature of the circulating liquid at the customer's equipment side is 29 ° C.

Mode	Description
MODE1	Conduct temperature control to make the outlet temperature of circulating fluid become the set temperature of circulating fluid + offset temperature. In addition, the circulating fluid display temperature shows the outlet water temperature of the circulating fluid.
MODE2	Conduct temperature control to make the outlet temperature of circulating fluid reach the set temperature of circulating fluid. In addition, the circulating fluid display temperature shows the spray temperature + offset temperature of the circulating fluid.
MODE3	Conduct temperature control to make the outlet temperature of circulating fluid become the set temperature of circulating fluid + offset temperature. In addition, the circulating fluid display temperature shows the spray temperature - offset temperature of the circulating fluid.
OFF	Conduct temperature control to make the spray temperature of circulating fluid become the set value of circulating fluid temperature.

Code	Item	Description	Factory setting
SE.04	Temperature Offset Mode	Set temperature offset mode	OFF
SE.05	Offset temperature	Set offset temperature	0.0°C

Set value	Description	Factory setting
OFF	Offset function off	○
md1	Temperature Offset Mode 1	
md2	Temperature Offset Mode 2	
md3	Temperature Offset Mode 3	

## 5) Offset temperature

Set value	Description	Factory setting
----	When the offset mode is OFF, it cannot be set and confirmed	OFF
°C -20~20	Set offset temperature Set temp unit: 0.1°C	0.0
°F -36~36	Set temp unit: 0.1°F	0.0

**CAUTION**



This function adjusts the offset temperature according to the circulating fluid discharge. The temperature range of circulating fluid of this product is controlled between 5.0°C and 40.0 °C (41.0 °F and 104.0 °F). When setting the set temperature of the circulating fluid to 5.0 °C (41.0 °F) and the offset temperature to - 20.0 °C (- 36.0 °F), please note that the offset temperature will be automatically adjusted to 0.0°C (0.0 °F) according to the offset mode.

## 6) Power failure reset

When the power supply is cut off due to power failure, it is the function to resume operation in the state before the power supply is cut off after the power supply is restored.

Code	Item	Description	Factory setting
SE.06	Power failure reset	Set whether the power-off reset function is enabled	OFF

Set value	Description	Factory setting
OFF	Power failure reset function is OFF.	○
ON	Power failure reset function is ON.	

## 7) Antifreeze function

This product can prevent circulating fluid from freezing in winter. If you are worried about freezing due to changes in the installation and use environment (use time, weather, etc.), please set it in advance.

When the circulating fluid temperature is lower than 3 ° C, the pump will run automatically.

When the pump is running, the circulating fluid is heated by the power of the pump.

When the circulating fluid temperature exceeds 5 ° C, the pump will stop automatically.

Repeat the automatic operation/stop of the pump and keep the circulating fluid temperature at 3°C~5°C to prevent freezing.

**CAUTION**



This function operates in standby mode (power switch ON).

- Fully open the valve and manual bypass valve of the customer's pipeline, and keep the circulating fluid in a recyclable state when the pump is running automatically.
- Under severe cold installation conditions, freezing may not be completely prevented.

**CAUTION**



Even if the "RUN/STOP" key is pressed during the automatic operation of the pump, the automatic operation of the pump will not stop. In case of emergency, please cut off the power and stop the operation.

Code	Item	Description	Factory setting
SE.07	Antifreeze function	Whether the antifreeze function is on.	OFF

Set value	Description	Factory setting
OFF	Antifreeze function is OFF.	○
ON	Antifreeze function is ON.	

## 8) Monitoring time of communication error

Set the monitoring time for the "communication error" alarm of alarm number AL12. When this monitoring time is exceeded, an alert will occur.

Code	Item	Description	Factory setting
SE.08	30 ~ 600	Set the monitoring time of communication error. Set the unit as 1 second.	30

## 9) Restore data to factory settings

### CAUTION



All settings are included. It is recommended to take extra care during operation and record the setting data before resetting the data.

Code	Item	Description	Factory setting
SE.09	Restore data to factory settings	Reset all data. (The accumulated running time is not reset).	NO

Set value	Description	Factory setting
ON	Do not reset.	○
YES	Full data reset.	

## 10) Cumulative time reset function

Code	Item	Description	Factory setting
SE.10	Accumulated time reset function of pump	Reset accumulated time of pump	NO
SE.11	Fan accumulative time reset function	Reset the fan cumulative time (only in the case of air cooled)	NO
SE.12	Compressor cumulative time reset function	Reset compressor cumulative time	NO

Set value	Description	Factory setting
ON	Do not reset.	○
YES	Reset accumulated time of pump	

Set value	Description	Factory setting
-----	Not resettable (only in water-cooled situations)	
ON	Do not reset.	○
YES	Reset turbine cumulative time	

Set value	Description	Factory setting
ON	Do not reset.	○
YES	Reset accumulated time of compressor	

## 11) PID

PID adjustment parameters can be set by users according to actual use.

Different model has different PID factory setting values.

Code	Item	Description
SE.13	"PID": "P" value	Proportional
SE.14	"PID": "I" value	Integral
SE.15	"PID": "D" value	Differentiate

## 12) Minimum outlet temperature setting of circulating fluid

Code	Item	Description	Factory setting
SE.16	-10~5	The minimum outlet water temperature of circulating liquid is set in °C.	5

### CAUTION



When the minimum outlet temperature of the circulating fluid is lower than 5 °C, the circulating fluid shall be 15% ethylene glycol in water.

## 13) Temperature Sensor Selection Settings

1. Select sensor operation method: Setting interface (first long press MENU to enter the checking and monitoring interface, then long press MENU to enter the setting interface) Under the setting interface, short press SEL to change the setting items to SE.17;

2. Shortly press the "up" key or "down" key to adjust the state setting. If SV shows "IN", the water temperature is monitored by the internal temperature sensor, if SV shows "OUT", the water temperature is monitored by the external backup temperature sensor.

3. The parameter value is automatically enabled after blinking for 3 seconds, or it can be directly enabled immediately by short pressing the SEL key.

Code	Item	Description	Factory setting
SE.17	IN or OUT temperature sensor	Choose internal or external temperature sensor to monitor the circulating fluid temperature	IN

#### 14) Circulating fluid conductivity

Code	Item	Description	Factory setting
SE.18	Maximum limit setting of circulating fluid conductivity	Setting the maximum limit of circulating fluid conductivity	50

#### 15) Circulating fluid pressure

Code	Item	Description	Factory setting
SE.19	Maximum circulating fluid pressure	Setting the maximum circulating fluid pressure	0.42
SE.20	Minimum circulating fluid pressure	Setting the minimum circulating fluid pressure	0.10

### 8.2.5.Communication setup page

The fourth page: Communication setup page.

Long press [MENU] key: enter the communication setup page.

Short press [MENU] key: return to the home page.

Short press [SEL] key: change inspection items. Connect the upper computer through serial port.

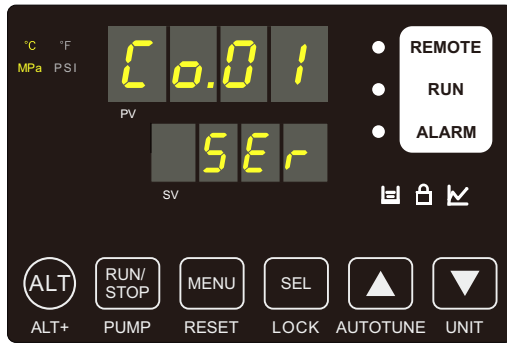

Code	Item	Description	Category	
Co.01	Communication mode	Set the communication mode of this	Communication setup page Contact input/output and serial communication	
Co.02	Communication specification	Set the specifications of serial communication		
Co.03	Simple communication protocol	Local address		Set local address
Co.04		Communication speed		Set communication speed
Co.05	Contact input signal 1	Set contact input signal 1		
Co.06	Contact input signal 1 form	Set contact input signal 1 input configuration		
Co.07	Contact input signal 1 reading delay time (delay time)	Set the read delay timer for contact input signal 1		
Co.08	Contact input signal 1 OFF detection timer	Set the OFF detection timer of contact input signal 1		
Co.09	Contact input signal 2	Set contact input signal 2		
Co.10	Contact input signal 2 form	Set contact input signal 2 input form.		
Co.11	Contact input signal 2 reading delay time (delay time)	Set the read delay timer for contact input signal 2		
Co.12	Contact input signal 2 OFF detection timer	Set the OFF detection timer of contact input signal 2		

Code	Item	Description	Category
Co.13	Contact input communication	Contact output signal 1 function	Set the output signal function of contact output 1
Co.14		Contact output signal 1 acts	Set the output signal function of contact output 1
Co.15		Contact output 1 selection alarm	Set the output signal alarm of contact output 1
Co.16		Contact output signal 2 function	Set the output signal function of contact output 2
Co.17		Contact output signal 2 acts	Set the output signal action of contact output 2
Co.18		Contact output 2 selection alarm	Set the output signal alarm of contact output 2
Co.19		Contact output signal 3 function	Set the output signal function of contact output 3
Co.20		Contact output signal 3 acts	Set the output signal action of contact output 3
Co.21		Contact output 3 selection alarm	Set the output signal alarm of contact output 3
			Communication setup page Contact input/output and serial communication

## 1) Communication mode

Code	Item	Description	Factory setting
Co.01	Communication mode	Set the communication mode of this product.	LOC

Set value	Description	Factory setting
LOC	Set LOCAL mode(Run and set through the operation display panel)	0
DIO	Set DIO mode(Run through the contact input/output )	
SER	Set SERIAL mode(Run and set through the serial communication)	

## 2) Communication specification

Code	Item	Description	Factory setting
Co.02	Communication specification	Set the communication specifications of this unit.	232

Set value	Description	Factory setting
232	RS-232C	0
485	Rs485	

### 3) Unit address

Code	Item	Description	Factory setting
Co.03	Unit address	Set the address of this unit.	1

Set value	Description	Factory setting
----	If the serial protocol setting is not a simple communication protocol, it cannot be set or confirmed	
1~99	The setting range of slave address for simple communication protocol is 1~99	1

### 4) Communication speed

Code	Item	Description	Factory setting
Co.04	Communication speed	Set the communication speed of this unit.	9.6

Set value	Description	Factory setting
----	If the serial protocol setting is not a simple communication protocol, it cannot be set or confirmed.	
1.2	1200bps	
2.4	2400bps	
4.8	4800bps	
9.6	9600bps	0
19.2	19200bps	

### 5) Set contact input signal 1

Code	Item	Description	Factory setting
Co.05	Contact input signal 1	Set the contact input signal 1	RUN

Set value	Description	Factory setting
OFF	No input signal	
RUN	Run/stop signal input	0
SV-A	External switch signal input (A connection)	
SV-B	External switch signal input (B connection)	

### 6) Contact input signal 1 form

Code	Item	Description	Factory setting
Co.06	Contact input signal 1 form	Set contact input signal 1 input configuration	ALT

Set value	Description	Factory setting
----	When the setting of contact input signal 1 is OFF, it cannot be set and confirmed	
ALT	Alternator signal	0
MT	Transient signal	

### 7) Contact input signal 1 reading delay time

Code	Item	Description	Factory setting
Co.07	Contact input signal 1 reading delay time (delay time)	Set the read delay timer for contact input signal 1	0

Set value	Description	Factory setting
----	When the setting of contact input signal 1 is outside the external switch signal input (A connection or B connection), it cannot be set and confirmed.	
0~300	Setting of contact input signal 1 read delay timer. Set the range from 0 to 300 seconds.	0

### 8) Contact input signal 1 OFF detection time

Code	Item	Description	Factory setting
Co.08	Contact input signal 1 OFF detection timer	Set the OFF detection timer of contact input signal 1	0

Set value	Description	Factory setting
----	When the setting of contact input signal 1 is outside the external switch signal input (A connection or B connection), it cannot be set and confirmed.	
0~10	Setting of contact input signal 1 OFF detection timer. Set the range from 0 to 10 seconds.	0

## 9) Set contact input signal 2

Code	Item	Description	Factory setting
Co.09	Contact input signal 2	Set contact input Signal 2	OFF

Set value	Description	Factory setting
OFF	No input signal	○
RUN	Run/stop signal input	
SV-A	External switch signal input (A connection)	
SV-B	External switch signal input (B connection)	

## 10) Contact input signal 2 form

Code	Item	Description	Factory setting
Co.10	Contact input signal 2 form	Set contact input Signal 2 input form	ALT

Set value	Description	Factory setting
----	When the setting of contact input signal 2 is OFF, it cannot be set and confirmed.	
ALT	Alternator signal	○
MT	Transient signal	

## 11) Contact input signal 2 read delay time

Code	Item	Description	Factory setting
Co.11	Contact input signal 2 read delay time	Set the read delay timer for contact input signal 2	0

Set value	Description	Factory setting
----	When the setting of contact input signal 2 is outside the external switch signal input (A connection or B connection), it cannot be set and confirmed.	
0~300	Setting of contact input signal 2 read delay timer. Set the range from 0 to 300 seconds.	0

## 12) Contact input signal 2OFF detection timer

Code	Item	Description	Factory setting
Co.12	Contact input signal 2OFF detection timer	Set the OFF detection timer of contact input signal 2	0

Set value	Description	Factory setting
----	When the setting of contact input signal 2 is outside the external switch signal input (A connection or B connection), it cannot be set and confirmed.	
0~10	Setting of contact input signal 2 OFF detection timer. Set the range from 0 to 10 seconds.	0

### 13) Contact output signal 1 function

Code	Item	Description	Factory setting
Co.13	Contact output signal 1 function	Set the output signal function of contact output 1	RUN

Set value	Description	Factory setting
OFF	No output signal	
RUN	Run signal output	○
RMT	Remote status signal output	
RDY	Ready to complete status signal (TEMP reading) output	
A.STP	Stop run alarm status signal output	
A.RUN	Run continuous alarm status signal output	
ALM	Alarm status signal output	
A.SEL	Select alarm status signal output	
ON.TM	Run start timer setting status signal output	
OF.TM	Run stop timer setting status signal output	
PRST	Power failure recovery set status signal output	
F.P.	Antifreeze setting status signal output	
INP1	Direct signal of contact input signal 1	
INP2	Direct signal of contact input signal 2	
A.FIL	Automatic water supply status signal	

## 14) Contact output signal 1 action

Code	Item	Description	Factory setting
Co.14	Contact output signal 1 Action	Set the output signal action of contact output 1	A

Set value	Description	Factory setting
A	A connection	O
B	B connection	

## 15) Contact output signal 1 selection alarm

Code	Item	Description	Factory setting
Co.15	Contact output signal 1 selection alarm	Set the output signal alarm of contact output 1	AL.01

Set value	Description	Factory setting
----	When the contact output 1 function is set to select the alarm status signal output, it cannot be set and confirmed.	
AL.01 AL.27	Set selection alarm Set the range from AL.01 to AL.27	AL.01

## 16) Contact output signal 2 function

Code	Item	Description	Factory setting
Co.16	Contact output signal 2 function	Set the output signal function of contact output 2	RMT

Set value	Description	Factory setting
OFF	No output signal	
RUN	Run signal output	
RMT	Remote status signal output	○
RDY	Ready to complete status signal (TEMP reading) output	
A.STP	Stop run alarm status signal output	
A.RUN	Run continuous alarm status signal output	
ALM	Alarm status signal output	
A.SEL	Select alarm status signal output	
ON.TM	Run start timer setting status signal output	
OF.TM	Run stop timer setting status signal output	
P.RST	Power failure recovery set status signal output	
F.P.	Antifreeze setting status signal output	
INP1	Direct signal of contact input signal 1	
INP2	Direct signal of contact input signal 2	
A.FIL	Automatic water supply status signal	

## 17) Contact output signal 2 action

Code	Item	Description	Factory setting
Co.17	Contact output signal 2 action	Set the output signal action of contact output 2	A

Set value	Description	Factory setting
A	A connection	○
B	B connection	

## 18) Contact output signal 2 selection alarm

Code	Item	Description	Factory setting
Co.17	Contact output signal 2 selection alarm	Set the output signal alarm of contact output 2	AL.01

Set value	Description	Factory setting
---	When the contact output 2 function is set to select the alarm status signal output, it cannot be set and confirmed.	
AL.01 AL.27	Set selection alarm Set the range from AL.01 to AL.27	AL.01

## 19) Contact output signal 3 function

Code	Item	Description	Factory setting
Co.17	Contact output signal 2 selection alarm	Set the output signal alarm of contact output 2	ALM

Set value	Description	Factory setting
OFF	No output signal	
RUN	Run signal output	
RMT	Remote status signal output	
RDY	Ready to complete status signal (TEMP reading) output	
A.STP	Stop run alarm status signal output	
A.RUN	Run continuous alarm status signal output	
ALM	Alarm status signal output	○
A.SEL	Select alarm status signal output	
ON.TM	Run start timer setting status signal output	
OF.TM	Run stop timer setting status signal output	
PRST	Power failure recovery set status signal output	
F.P.	Antifreeze setting status signal output	
INP1	Direct signal of contact input signal 1	
INP2	Direct signal of contact input signal 2	
A.FIL	Automatic water supply status signal	

## 20) Contact output signal 3 action

Code	Item	Description	Factory setting
Co.20	Contact output signal 3 action	Set the output signal action of contact output 3	B

Set value	Description	Factory setting
A	A connection	
B	B connection	O

## 21) Contact output signal 3 selection alarm

Code	Item	Description	Factory setting
Co.21	Contact output signal 3 selection alarm	Set the output signal alarm of contact output 3	AL.01

Set value	Description	Factory setting
----	When the contact output 3 function is set to select the alarm status signal output, it cannot be set and confirmed.	
AL.01 AL.27	Set selection alarm Set the range from AL.01 to AL.27	AL.01

## 9. Alarm

### 9.1. Alarm code list (Display in main interface SV only when an alarm occurs)

Code	Description	Status	May reason · Repair method (After eliminate the causes, press the [Reset] key)	Category
AL01	Low fluid level	Stop	Low fluid level. Add fluid.	Alarm display menu Display the alarm number when an alarm occurs.
AL02	Circulating fluid high temp ( 45°C )	Stop	Check ambient temperature and thermal load. Wait for the drop of temperature.	
AL03	Circulating fluid high temp ( 60°C )	Stop	Ensure the circulating fluid capacity is more than 5L/min Ensure that the thermal load is within the specification range.	
AL04	Circulating fluid pressure higher than set value SE.19	Stop	Check whether the customer's piping is broken, crushed and blocked.	
AL05	Circulating fluid pressure Lower than set value SE.20	Stop	Restart and check whether the pump is running	
AL06	Compressor high temp error ( 80°C )	Stop	Restart and check whether the pump is running	
AL07	Compressor low suction temp error ( -15°C )	Stop	Ensure circulating fluid flow. Check whether the circulating fluid in the evaporator is frozen. Use 15% ethylene glycol in water when the temperature is lower than 0°C	
AL08	Superheat drop error ( Compressor suction temperature minus the temperature corresponding to the suction pressure gauge is less than 3°C )	Stop		
AL09	Compressor high pressure error ( 4MPa )	Stop	Check ambient temperature and thermal load.	
AL10	Compressor suction or discharge pressure drops	Stop	Ensure that the ambient temperature is within the specification range. Technical support is required.	
AL11	Compressor overload	Stop	Restart after 10 minutes.	
AL12	Communication error	Stop	You have not received a request message from the host. Please send the request message again.	
AL13	Reservoir error	Stop	Write data and read data are different. Technical support is required.	

AL14	DC line fuse open	Stop	Communication connector for input and output contact. Fuse broken. Technical support is required. Check whether the wiring is correct and whether the load exceeds 500mA.	Alarm display menu Display the alarm number when an alarm occurs.
AL15	Circulating fluid output temperature sensor error	Stop	Temperature sensor short circuit or open circuit. Technical support is required.	
AL16	Circulating fluid return temperature sensor error	Stop		
AL17	Compressor suction temperature sensor error	Stop		
AL18	Circulating fluid output pressure sensor error	Stop	Pressure sensor short circuit or open circuit. Technical support is required.	
AL19	Compressor output pressure sensor error	Stop		
AL20	Compressor suction pressure sensor error	Stop		
AL21	Pump maintenance ( Run exceed 20000h )	Continue	Notice of regular inspection.Please check the pump, fan motor and compressor.	
AL22	Fan motor maintenance ( Run exceed 20000h )	Continue		
AL23	Compressor maintenance ( Run exceed 50000h )	Continue		
AL24	Port contact input 1 signal detection	Stop	Port contact input detected.	
AL25	Port contact input 2 signal detection			
AL26	Water leakage	Stop	Make sure the water leakage sensor is connected. Fluid leakage occurs. Check the leakage area.	
AL27	The conductivity of the circulating fluid exceeds the upper limit		The circulating fluid is dirty, replace the clean circulating fluid.	

## 10. Appendix

The signal and shape of each connector and the method to calculate dew point are explained below.

### 10.1. Signal and style of connectors

The signal and style of each connector attached to the Chiller are as shown on the table below.

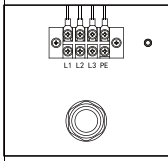
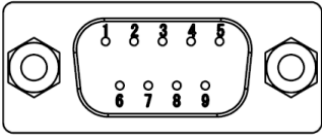
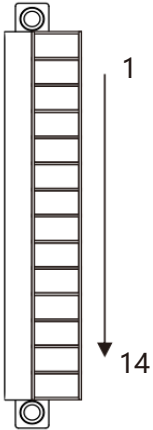
Description	No.	Signal	Style and Part No.
Power supply connector ( TB2504 )	L1	AC380-415V	
	L2	AC380-415V	
	L3	AC380-415V	
	PE	PE	
RS232/485	1	A	
	2	RXD	
	3	TXD	
	4	NC	
	5	GND	
	6-8	NC	
	9	B	
Communication connector  Alarm Output connector  External temperature sensor connector	1	Interface input signal 1	
	2	Interface input signal 1	
	3	Interface input signal 2	
	4	Interface input signal 2	
	5	Interface input signal 3	
	6	Interface input signal 3	
	7	Interface output signal 1	
	8	Interface output signal 1	
	9	Interface output signal 2	
	10	Interface output signal 2	
	11	Interface output signal 3	
	12	Interface output signal 3	
	13	24V+	
	14	0V	

List10-1 Signal and style of connectors

## 10.2. Calculation of dew point (from psychrometric chart)

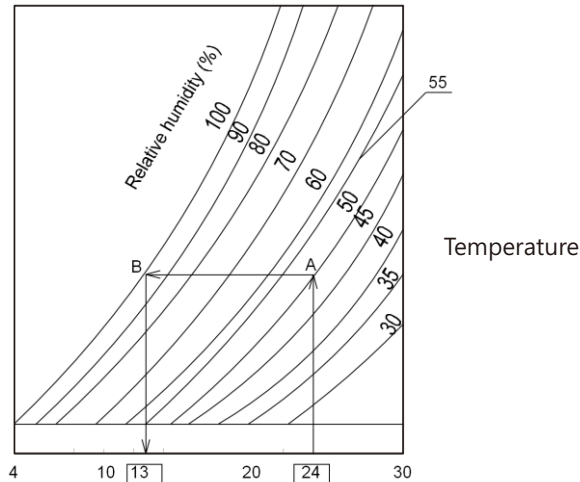

Fig.10-1 Moisture air diagram

- 1) Measure the ambient temperature and relative humidity.
  - 2) Plot the ambient temperature on the horizontal axis (Ex. 24°C), and then draw a perpendicular line.
  - 3) Find the intersection (A) of the curve, which is equal to relative humidity (Ex. 50%).
  - 4) Draw a line from point (A) parallel to horizontal axis, and find the intersection (B) of the curve for 100% relative humidity.
  - 5) Draw a perpendicular line from the intersection at point (B) down to the horizontal axis and read the Dew Point Temperature. (13 °C in this case)
- Therefore, moisture in the air starts to condensate when the air temperature becomes lower than this temperature.

## 10.3. Power Supply Cable

### CAUTION

Do not use the included power supply cable for any purposes other than connection to this product.

## 10.4. Refrigerant temperature and pressure comparison table

R410A refrigerant temperature and pressure comparison table					
Temperature °C	Absolute pressure Mpa	Temperature °C	Absolute pressure Mpa	Temperature °C	Absolute pressure Mpa
-20	0.40	7	1.00	34	2.09
-19	0.42	8	1.03	35	2.14
-18	0.43	9	1.06	36	2.20
-17	0.45	10	1.09	37	2.25
-16	0.46	11	1.12	38	2.31
-15	0.48	12	1.26	39	2.37
-14	0.50	13	1.29	40	2.43
-13	0.52	14	1.33	41	2.49
-12	0.54	15	1.37	42	2.55
-11	0.55	16	1.41	43	2.61
-10	0.57	17	1.45	44	2.67
-9	0.59	18	1.37	45	2.73
-8	0.62	19	1.41	46	2.80
-7	0.64	20	1.45	47	2.86
-6	0.66	21	1.49	48	2.93
-5	0.68	22	1.53	49	3.00
-4	0.70	23	1.57	50	3.07
-3	0.73	24	1.61	51	3.14
-2	0.75	25	1.66	52	3.21
-1	0.78	26	1.70	53	3.29
0	0.80	27	1.75	54	3.36
1	0.83	28	1.79	55	3.44
2	0.85	29	1.84	56	3.52
3	0.88	30	1.89	57	3.60
4	0.91	31	1.94	58	3.68
5	0.94	32	1.99	59	3.76
6	0.97	33	2.04	60	3.84

R32 refrigerant temperature and pressure comparison table

Temperature °C	Absolute pressure Mpa	Temperature °C	Absolute pressure Mpa	Temperature °C	Absolute pressure Mpa
-20	0.406	7	1.011	34	2.135
-19	0.421	8	1.042	35	2.19
-18	0.437	9	1.074	36	2.245
-17	0.454	10	1.107	37	2.302
-16	0.471	11	1.14	38	2.359
-15	0.488	12	1.174	39	2.418
-14	0.506	13	1.209	40	2.478
-13	0.524	14	1.244	41	2.539
-12	0.543	15	1.281	42	2.601
-11	0.563	16	1.318	43	2.664
-10	0.573	17	1.356	44	2.729
-9	0.603	18	1.394	45	2.794
-8	0.624	19	1.434	46	2.861
-7	0.646	20	1.474	47	2.929
-6	0.668	21	1.516	48	2.999
-5	0.691	22	1.558	49	3.069
-4	0.714	23	1.601	50	3.141
-3	0.738	24	1.645	51	3.214
-2	0.762	25	1.689	52	3.288
-1	0.787	26	1.735	53	3.364
0	0.813	27	1.782	54	3.441
1	0.839	28	1.829	55	3.52
2	0.866	29	1.878	56	3.599
3	0.894	30	1.927	57	3.681
4	0.922	31	1.978	58	3.763
5	0.951	32	2.029	59	3.847
6	0.981	33	2.082	60	3.933



Hangzhou Dahe Thermo-Magnetics CO.,Ltd.

Address: No.668 Binkang Road, Binjiang District, Hangzhou City,  
Zhejiang 310053, P.R.China

Pre sales technical consultation: 15967138668

After sales service hotline: (+86)-0571-86695070

Post code: 310053

Fax: 021-6432 5393

E-mail: wangyf@ferrotec.com.cn

URL: [www.ferrotec.com.cn](http://www.ferrotec.com.cn)

---

Note: Specifications are subject to change without prior notice and any obligation on the part of the manufacturer. © 2023 FerroTec Corporation All Rights Reserved