



Peltier-Type Chiller

Model		FCTC50101-2101	
Cooling mode		Thermoelectric device(Thermo-module)	
Ambient temperature/humidity		10-35°C, 35-80%RH (Without condensation)	
Radiating method		Forced water cooling	
Control method		Cooling/Heating Automatic shift PID control	
Refrigeration unit	Circulating fluid system	Circulating fluid	Pure water, hydrofluoric acid, ammonia, hydrogen peroxide solution
		Circulating line flow/pressure	Maximum allowable pressure:0.35MPa Maximum flow rate:17L/min
		Operating temperature range	10.0-60.0°C
		Cooling Power	500W (Ambient temperature 25°C, cooling water temperature 25°C, cooling water flow rate 5L/min)
		Heating Power	1100W (Ambient temperature 25°C, cooling water temperature 25°C, cooling water flow rate 5L/min)
		Temperature stability	±0.1°C (Stable turbulence)
		Port size(IN/OUT)	3/4 inch PFA tube
	Wetted parts material	PFA, Perfluoroelastomer	
	Facility water system	Temperature range	10-35°C (Without condensation)
		Pressure range	≤0.5MPa
		Required flow rate	5-10L/min
		Port size (S-IN/S-OUT)	3/8 inch PFA tube
		Tank capacity	Approx. 20L
Wetted parts material		PFA, SUS304, SUS316	
Weight	13.6kg		
Electrical system	Power supply	HRPG-1000-48 AC100-240V, single phase, 50/60Hz	
	Overcurrent protection	14.5A	
	Current consumption	3.43A	
	Weight	5.4kg	
	Communication	RS-485, ETH, RS-232C	
Accessories		Power cable	
Safety standards		EN 61010-1:2010/A1:2019	

Peltier - Type Chiller

Parts Description

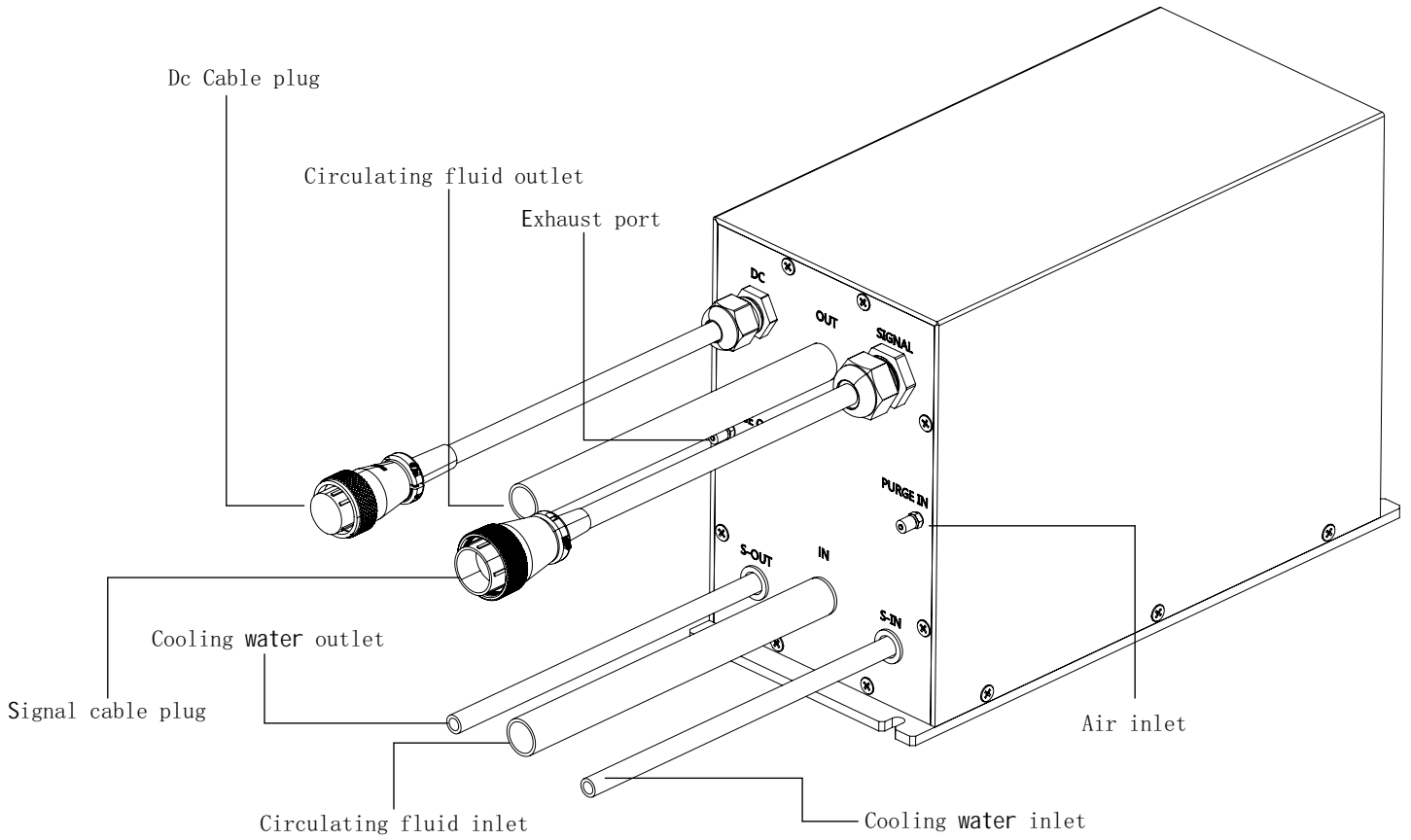

Parts Description

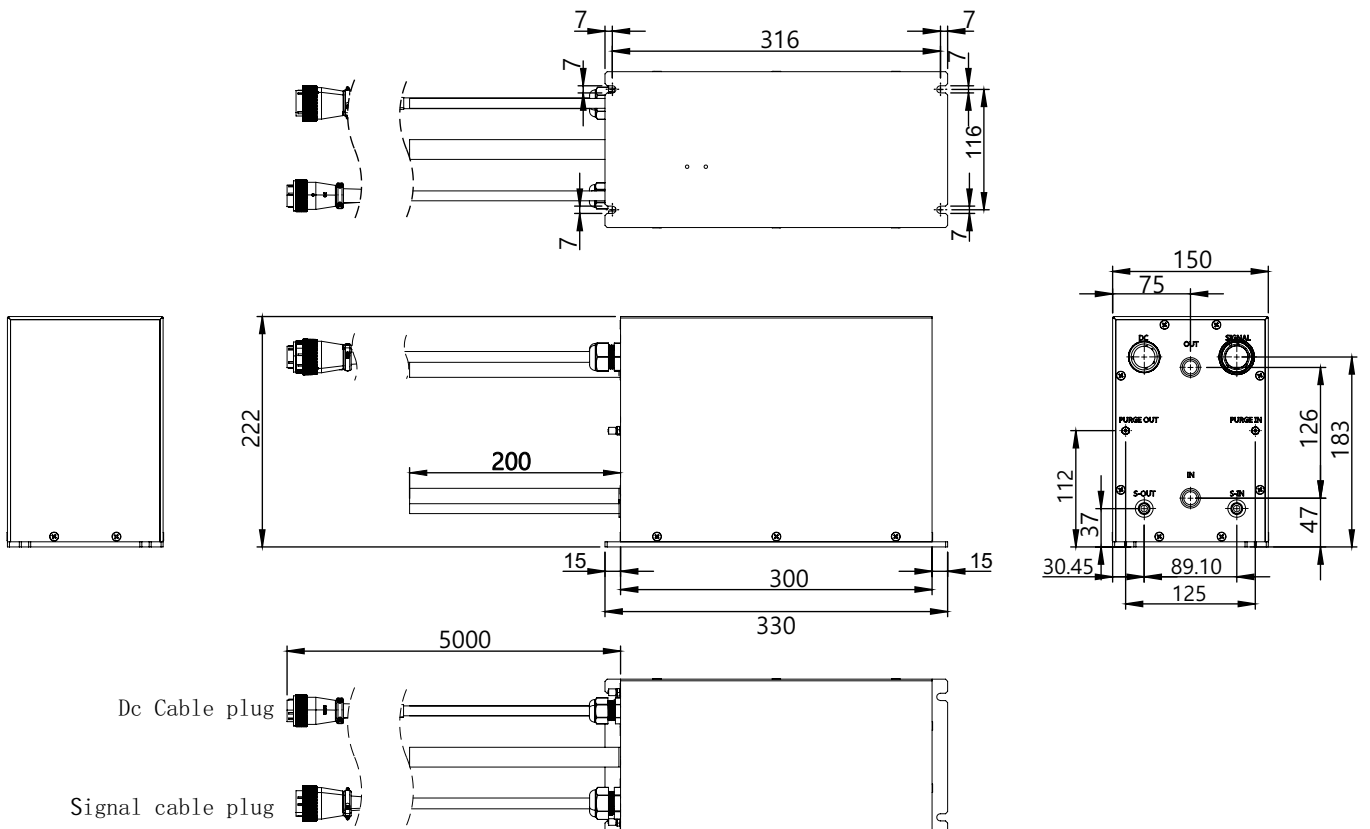

Peltier - Type Chiller

Parts Description

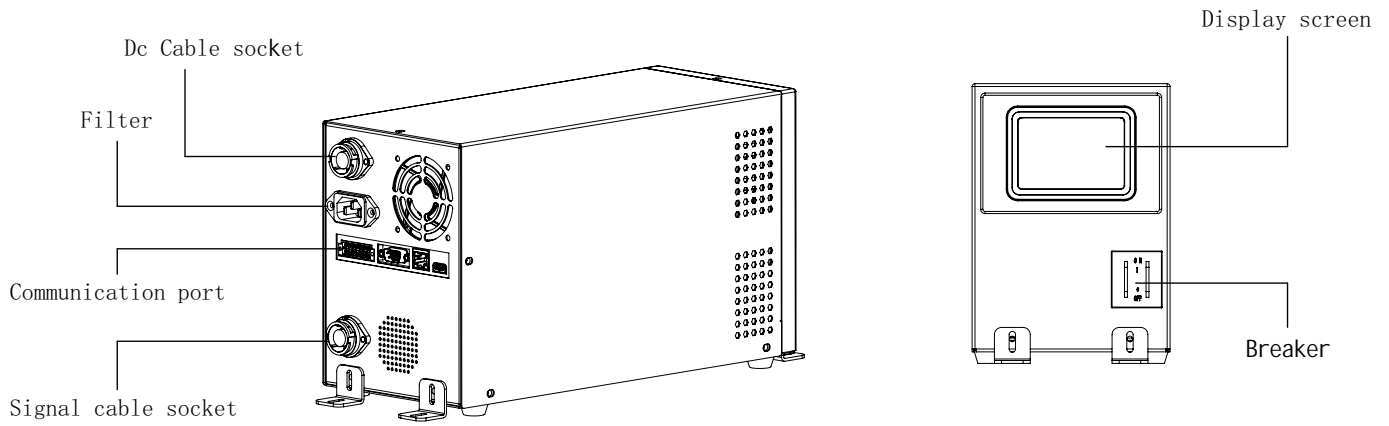

Parts Description

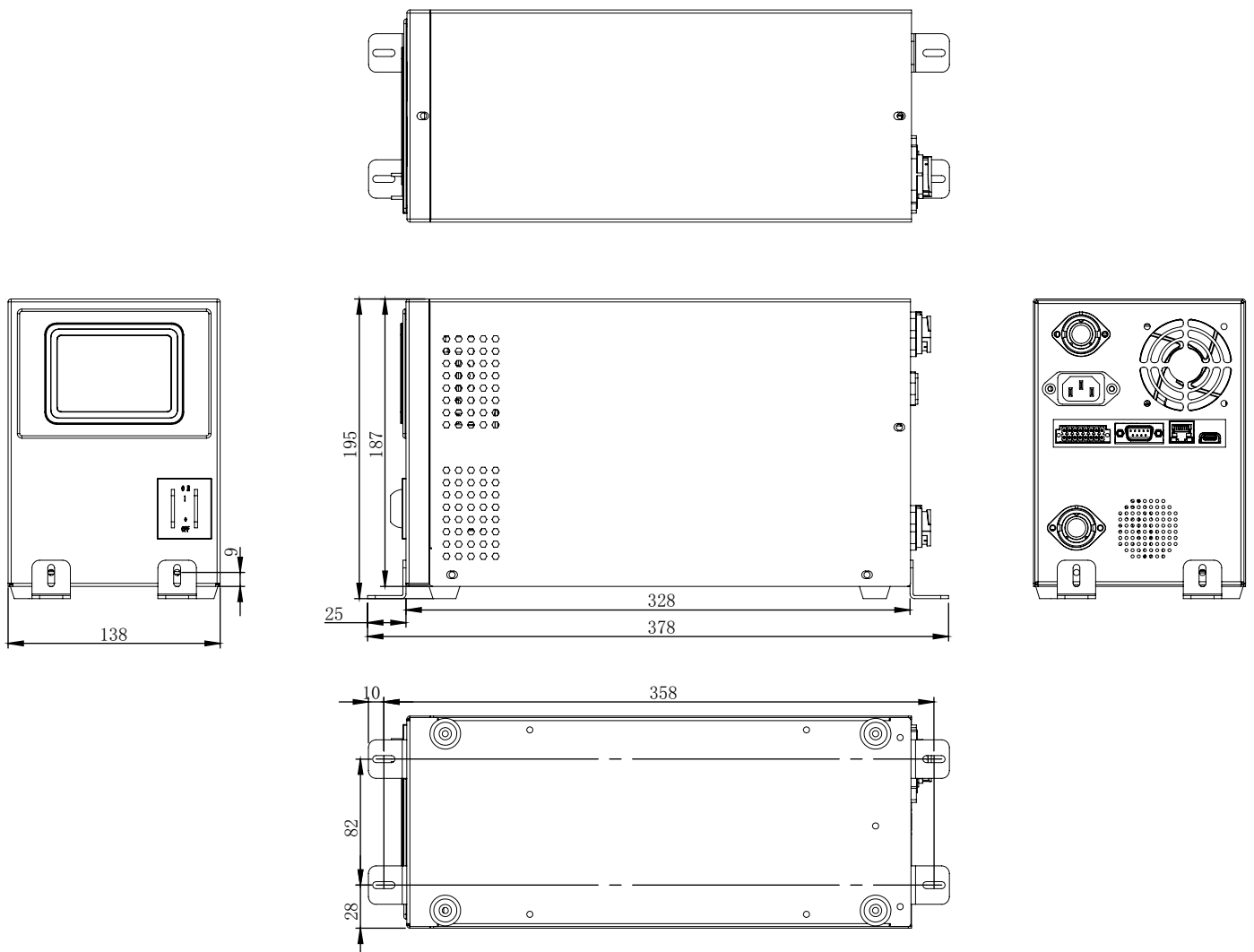

Peltier - Type Chiller

Parts Description

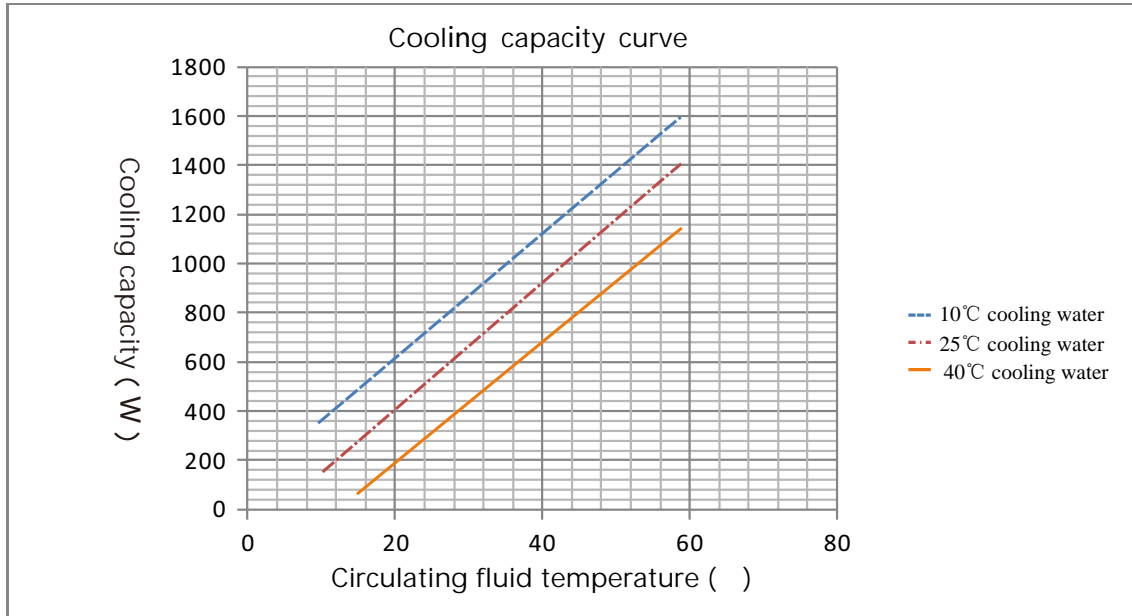

Parts Description

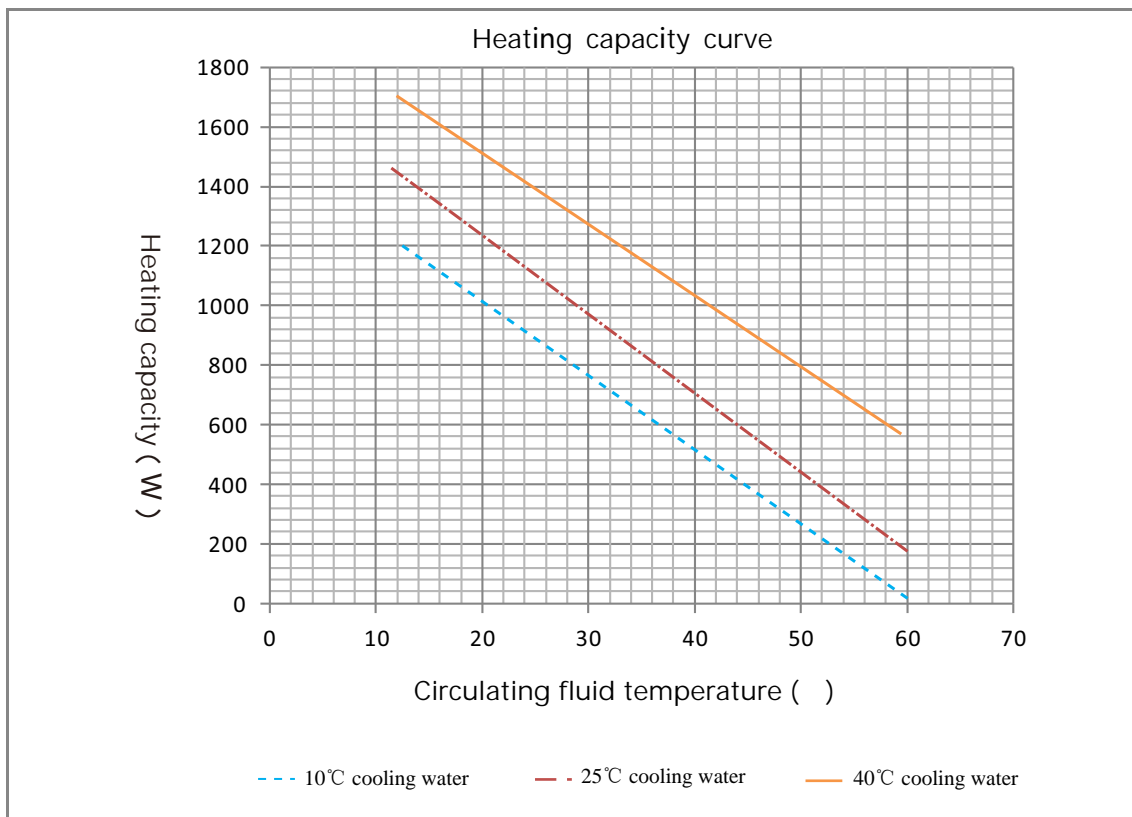

Peltier - Type Chiller

Parts Description

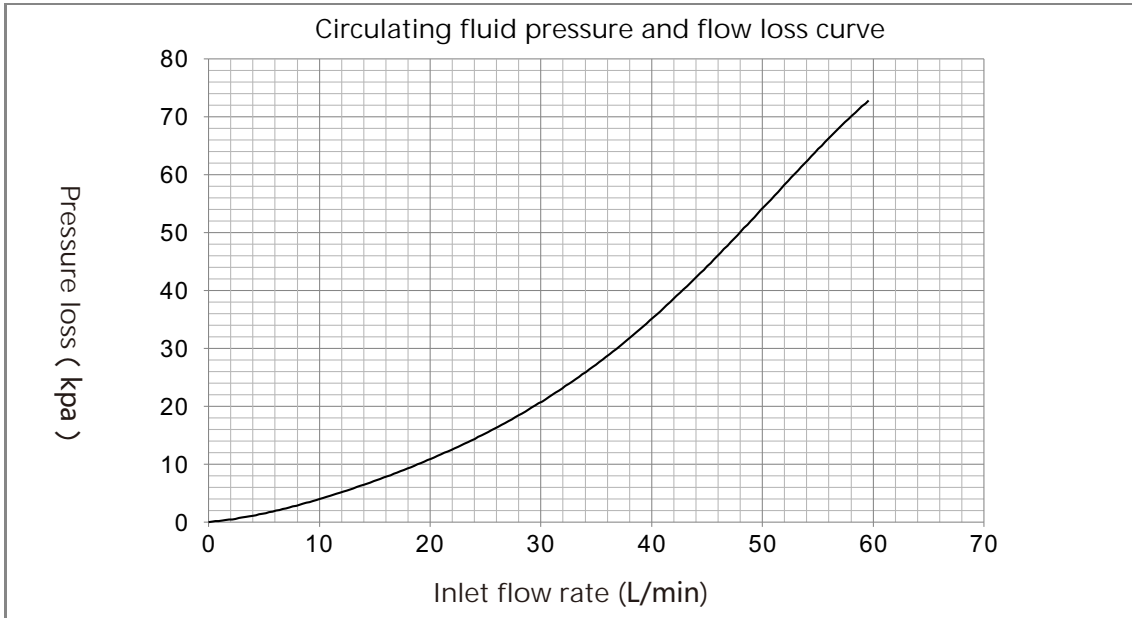

Parts Description

