



集成式冷水机-半导体制冷式 Integrated Chiller - Peltier Type

Model 型号		FCSI06091	
Cooling method 制冷方式		Thermoelectric device (Thermo-module) 热电半导体	
Radiating method 散热方式		Forced fluid cooling 强制液体冷却	
Control method 控制方式		Cooling/Heating automatic shift PID control 制冷/制热 PID控制	
Ambient temperature/humidity 环境温度/湿度		10~35° C, 35~80%RH	
Interactive/display 交互/显示		10-inch touchscreen 10英寸触摸屏	
Number of integrated chillers 集成冷水机数量		300W×6 units 300W×6台	
Number of integrated TEC temperature controllers 集成TEC温控器数量		9 units	
Circulating fluid system 循环系统	Circulating fluid 循环流体		DI Water 纯水
	Operating temperature range 工作温度范围		10.0~60.0° C
	Temperature stability 温度稳定性		±0.05° C
	Port size 接口尺寸	IN/OUT 冷却水进口/冷却水出口	Inner and outer diameter of the tube 16×13mm 管子内外径16×13mm
		IN/OUT 进水口/出水口	Inner and outer diameter of the tube 12×9mm 管子内外径12×9mm
		Drain 排水口	Inner and outer diameter of the tube 12×9mm 管子内外径12×9mm
Wetted parts material 接触液体零件材质		Stainless steel 304, EPDM, PE, ABS 304不锈钢, EPDM, PE, ABS	
Electrical system 电气系统	Power supply 电源		Three-phase 208V, 50/60 Hz 三相208V, 50/60 Hz
	Overcurrent protector 过载电流		40A
	Communication port 通讯端口		RS-485
	Communication protocol 通讯协议		Modbus rtu
Weight 整机重量		Approx. 210kg 约210kg	
Chiller 冷水机	Cooling capacity 制冷量		300W (25° C) ※ 1
	Heating capacity 制热量		680W (25° C) ※ 1
	Temperature stability 温度稳定性		±0.05° C ※ 2
	Pump 泵		Magnetic drive pump 22L/min, 11m lift 磁力泵 22L/min, 11m扬程
	Tank capacity 水箱容量		Approx. 1.2 L 约1.2L
	Weight 重量		Approx. 10.25kg 约10.25kg
	Safety standards 安全标准		EN61010-1 CE marking EN61010-1 CE标识

※ 1 Ambient temperature 25° C, Set temperature 25° C, Circulating 5.5L/min
环境温度25° C, 设定温度25° C, 循环流量5.5L/min

※ 2 Value under stable load without turbulence
在稳定的负载且无紊乱气流下的数值

TEC temperature controller component TEC温度控制器组件	Output voltage 输出电压	12V-48V
	Rated output current 额定输出电流	0-20A
	Switching power supply 开关电源	24V 600W ※3
	Temperature resolution 温度分辨率	0.01℃
	Temperature control range 控制温度范围	-199.99℃~99.99℃
	Temperature stability 温度稳定性	±0.05℃
	Protective function 保护功能	Short circuit protection、Overload protection、Overheating protection 短路保护、过载保护、超温保护
	Cooling method 散热方式	Forced air cooling 强制风冷
	Weight 重量	Approx. 4kg 约4kg

※ 3 根据客户需求选配。

集成式冷水机-半导体制冷式 Integrated Chiller - Peltier Type

Parts Description

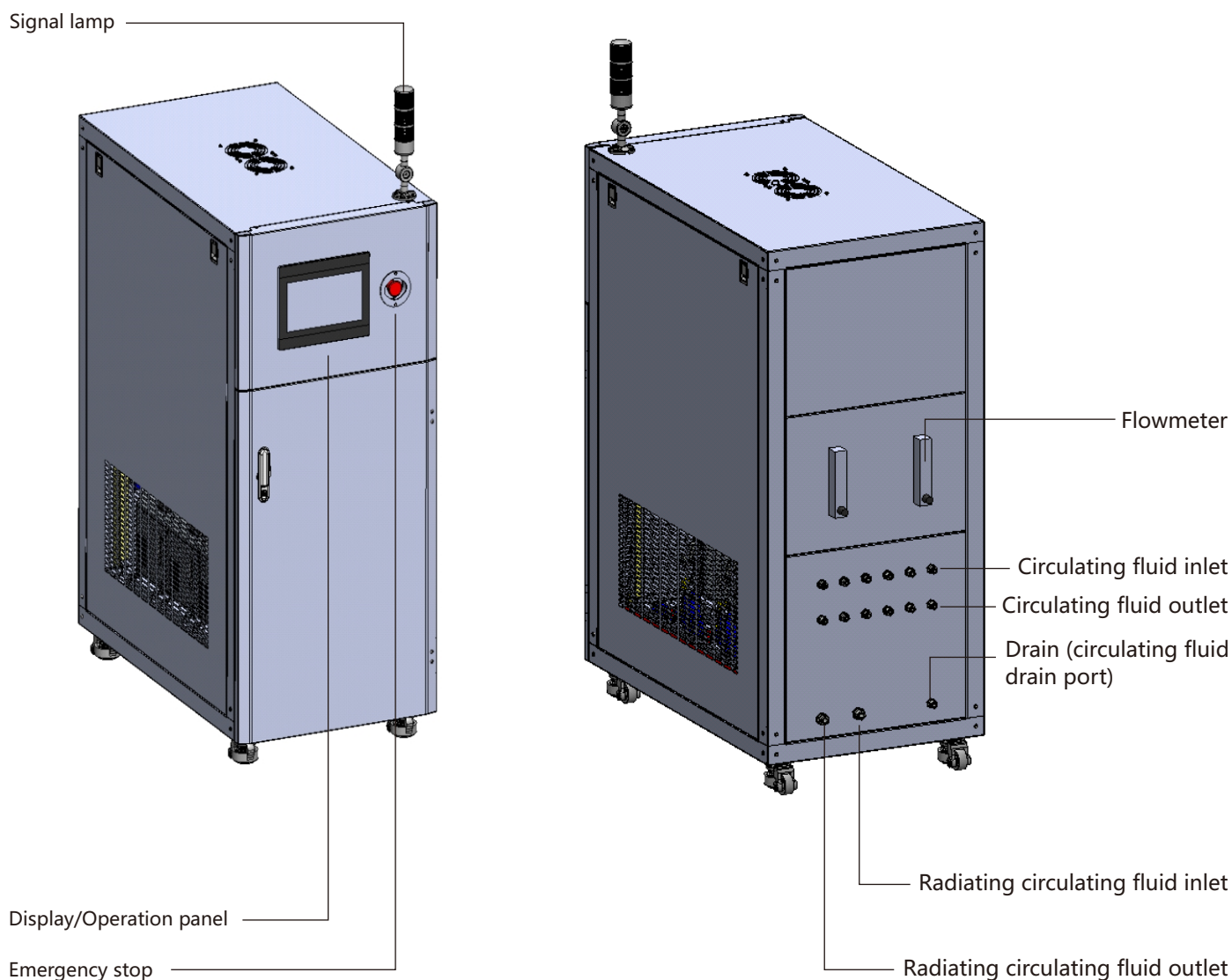

Parts Description

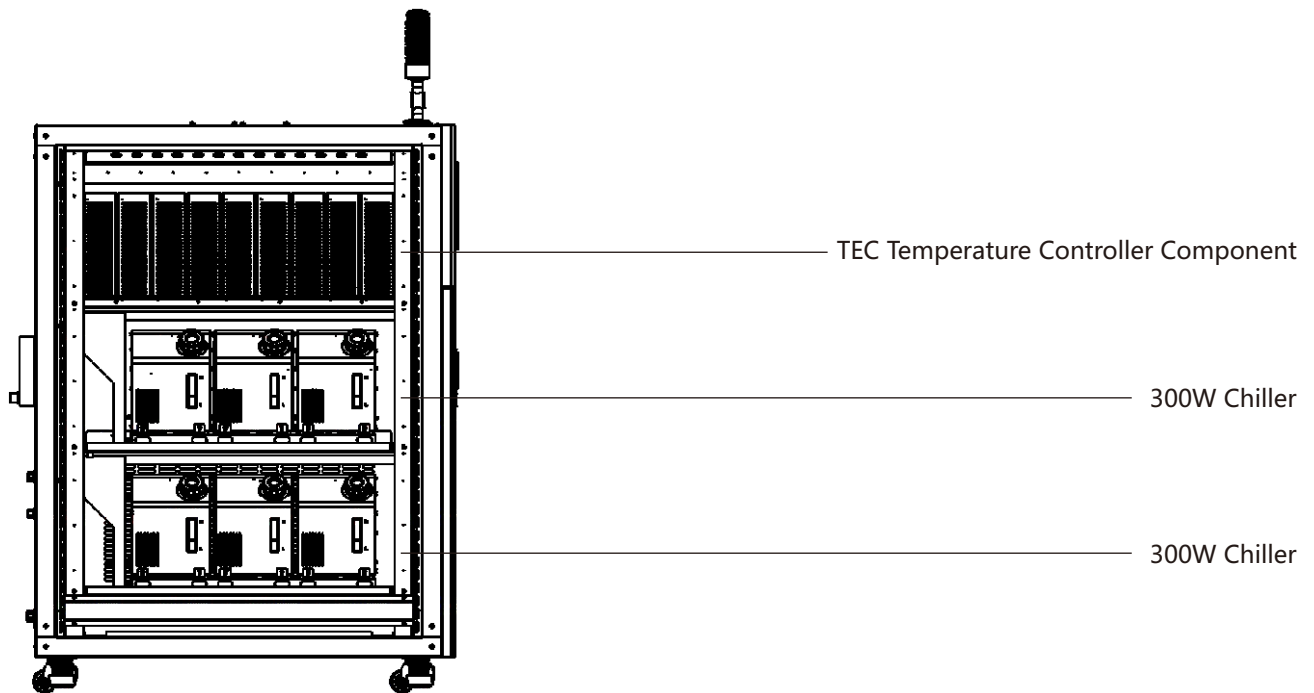

FCSW0022301涂胶显影机用集成温控器、6台300W冷水机、9台TEC温控器组件

Parts Description

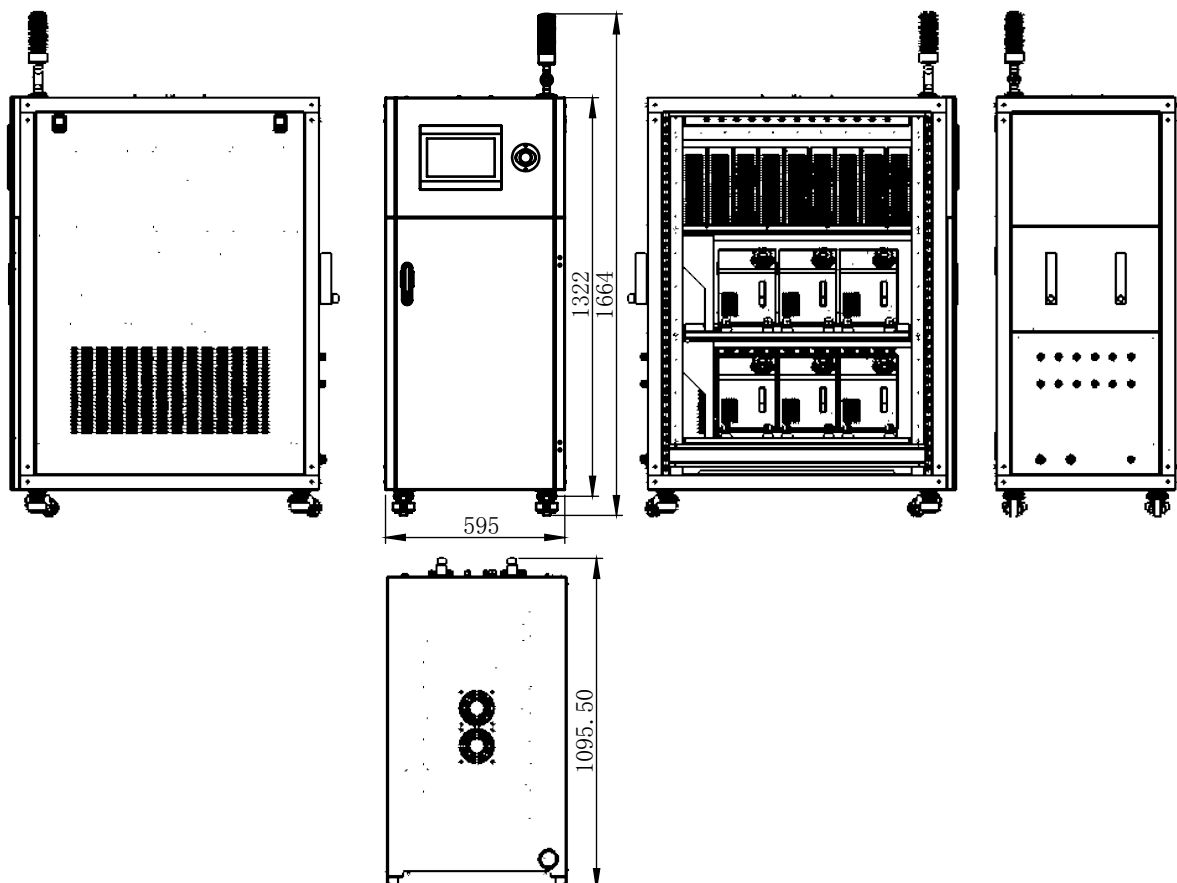

冷水机-半导体制冷式 Peltier - Type Chiller

Parts Description

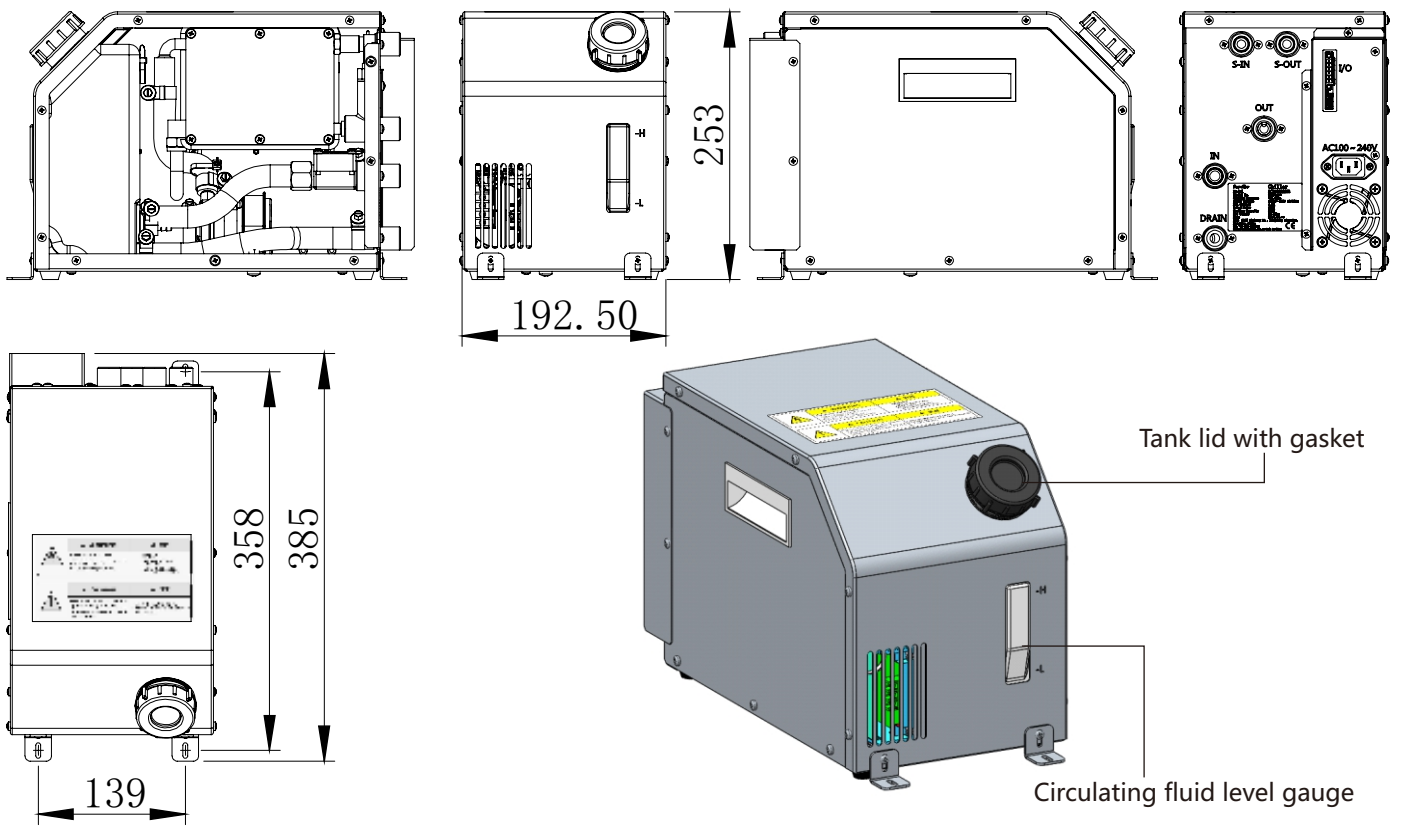

TEC温控器组件 TEC Temperature Controller Component

Parts Description

